



جامعة فلسطين التقنية - خضوري
Palestine Technical University - Kadoorie

Digital Electronics and Logic Design Introduction

Dr. Jafar Saifeddin Jallad

Dept. of Electrical Engineering

Palestine Technical University

Tulkaram, Palestine

Summary

Analog Quantities

Most natural quantities that we see are **analog** and vary continuously. Analog systems can generally handle higher power than digital systems.

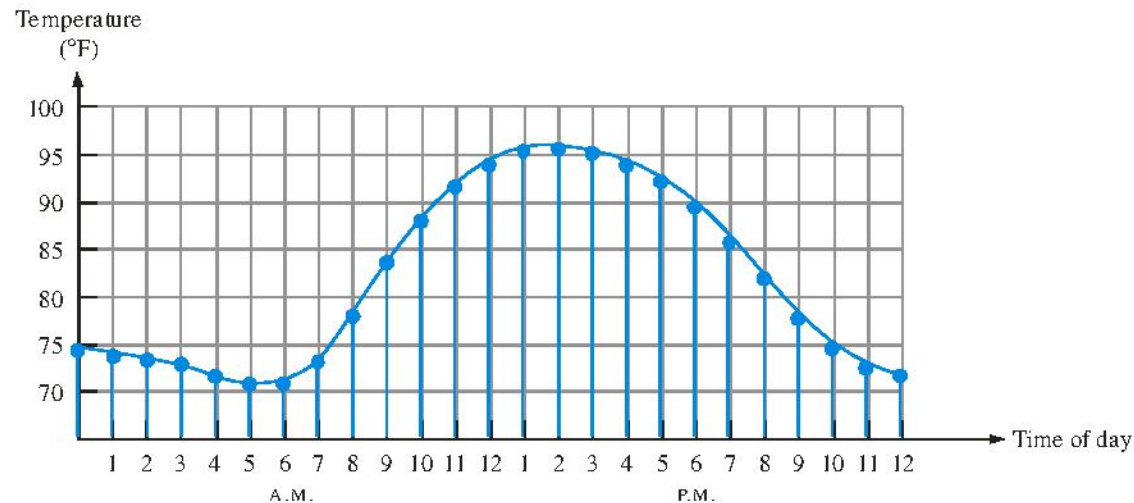

Digital systems can process, store, and transmit data more efficiently but can only assign discrete values to each point.

Summary

Analog and Digital Systems

Many systems use a mix of analog and digital electronics to take advantage of each technology. A typical CD player accepts digital data from the CD drive and converts it to an analog signal for amplification.

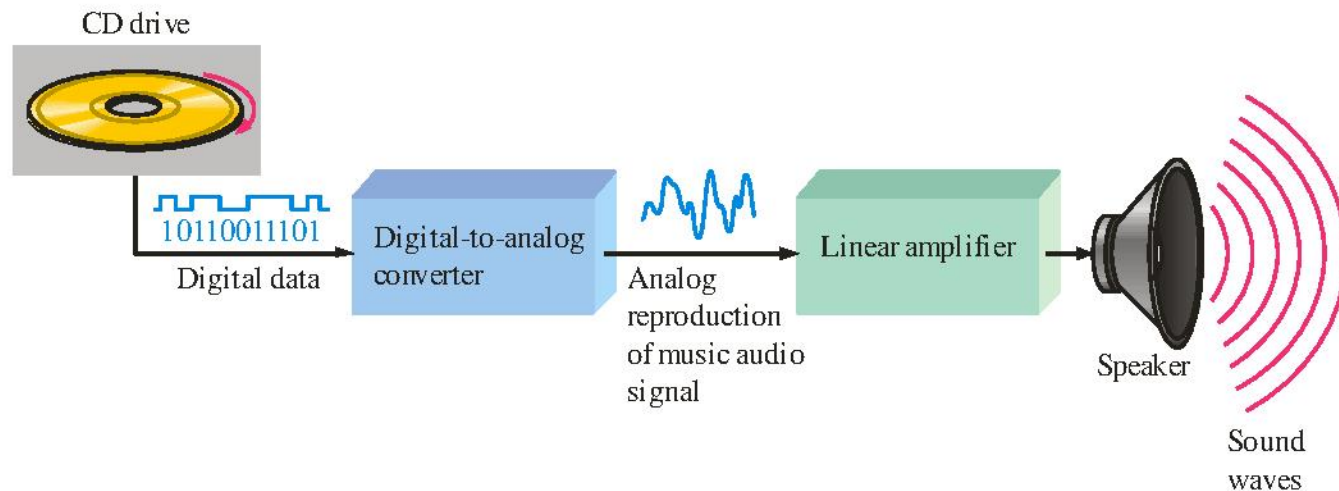

Summary

Binary Digits and Logic Levels

Digital electronics uses circuits that have two states, which are represented by two different voltage levels called HIGH and LOW. The voltages represent numbers in the binary system.

In binary, a single number is called a *bit* (for *binary digit*). A bit can have the value of either a 0 or a 1, depending on if the voltage is HIGH or LOW.

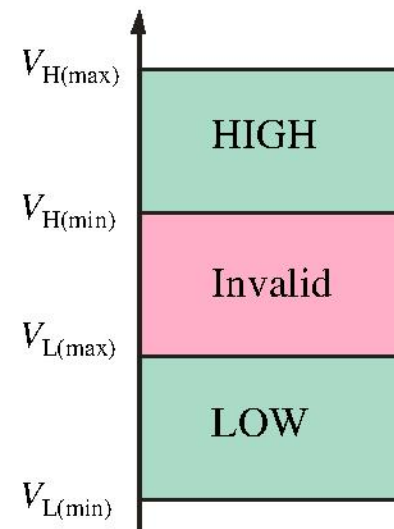

Summary

Digital Waveforms

Digital waveforms change between the LOW and HIGH levels. A positive going pulse is one that goes from a normally LOW logic level to a HIGH level and then back again. Digital waveforms are made up of a series of pulses.

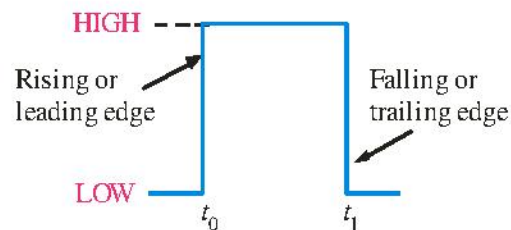

(a) Positive-going pulse

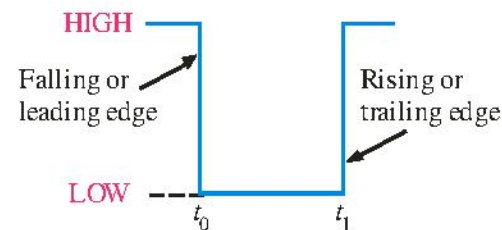

(b) Negative-going pulse

Summary

Pulse Definitions

Actual pulses are not ideal but are described by the rise time, fall time, amplitude, and other characteristics.

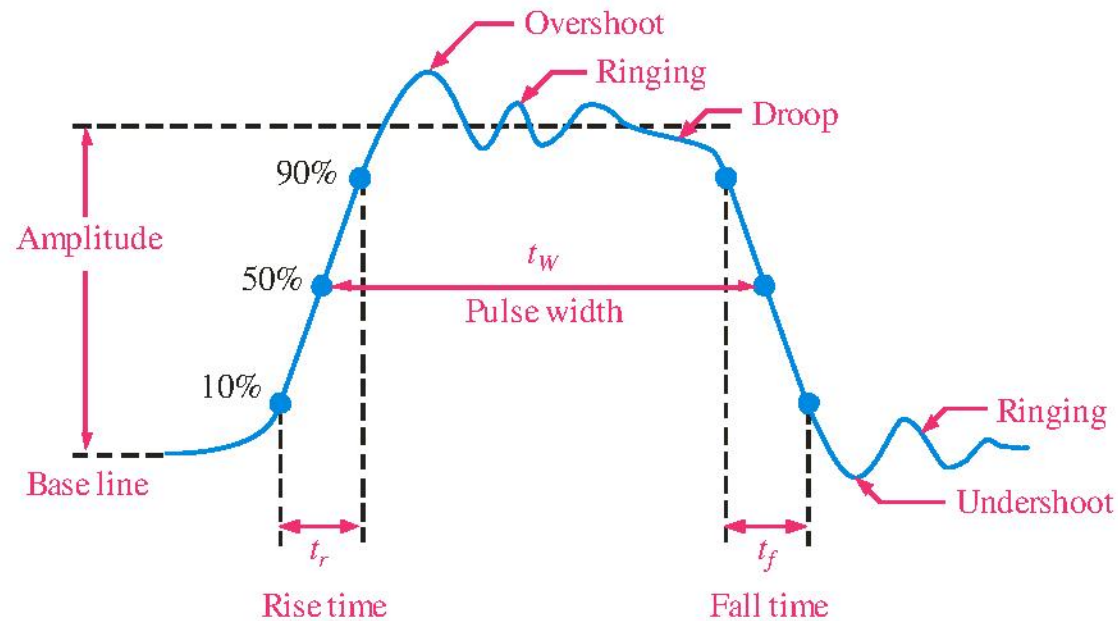

Summary

Periodic Pulse Waveforms

Periodic pulse waveforms are composed of pulses that repeats in a fixed interval called the **period**. The **frequency** is the rate it repeats and is measured in hertz.

$$f = \frac{1}{T} \qquad T = \frac{1}{f}$$

The **clock** is a basic timing signal that is an example of a periodic wave.

Example

What is the period of a repetitive wave if $f = 3.2 \text{ GHz}$?

Solution

$$T = \frac{1}{f} = \frac{1}{3.2 \text{ GHz}} = 313 \text{ ps}$$

Summary

Pulse Definitions

In addition to frequency and period, repetitive pulse waveforms are described by the amplitude (A), pulse width (t_W) and duty cycle. Duty cycle is the ratio of t_W to T .

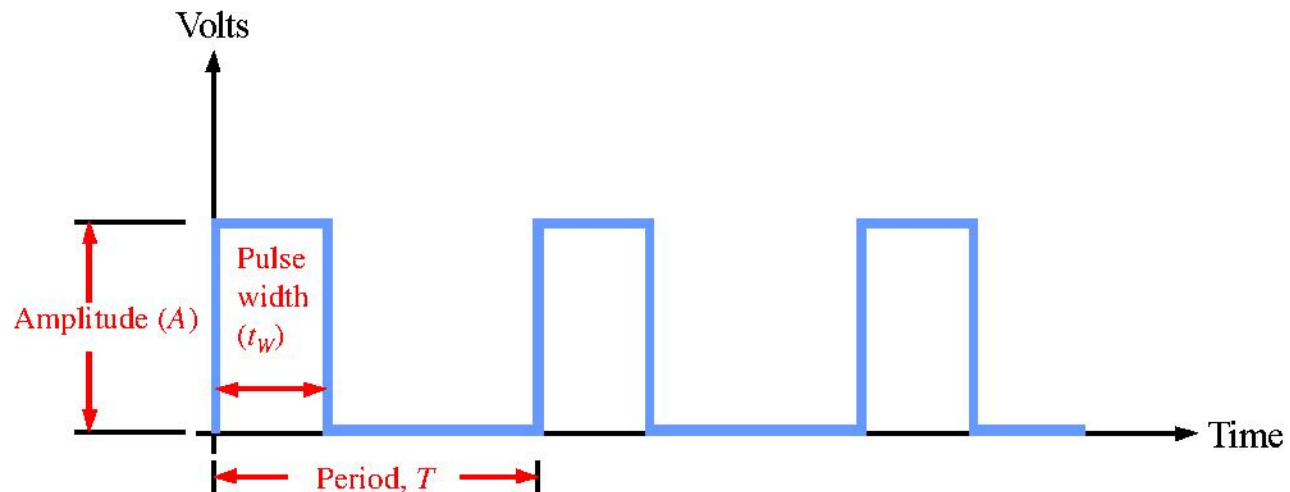

Summary

Timing Diagrams

A timing diagram is used to show the relationship between two or more digital waveforms,

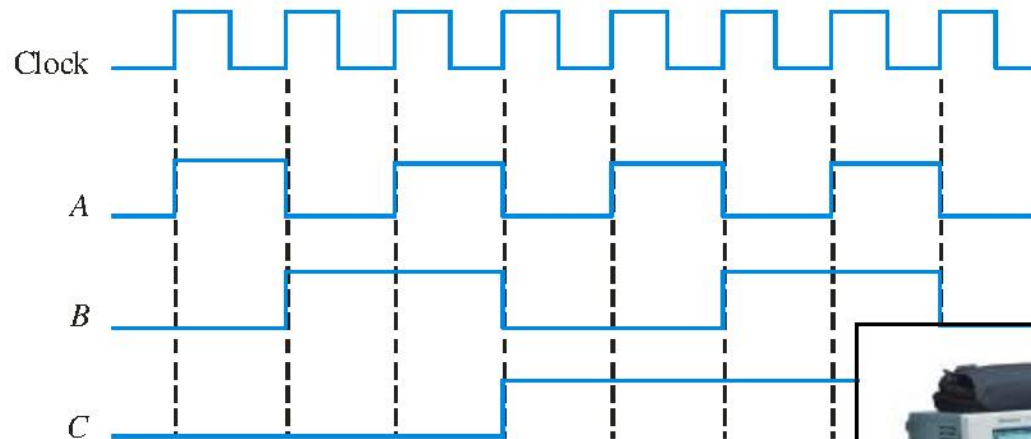

A diagram like this can be observed directly on a logic analyzer.



Summary

Serial and Parallel Data

Data can be transmitted by either serial transfer or parallel transfer.

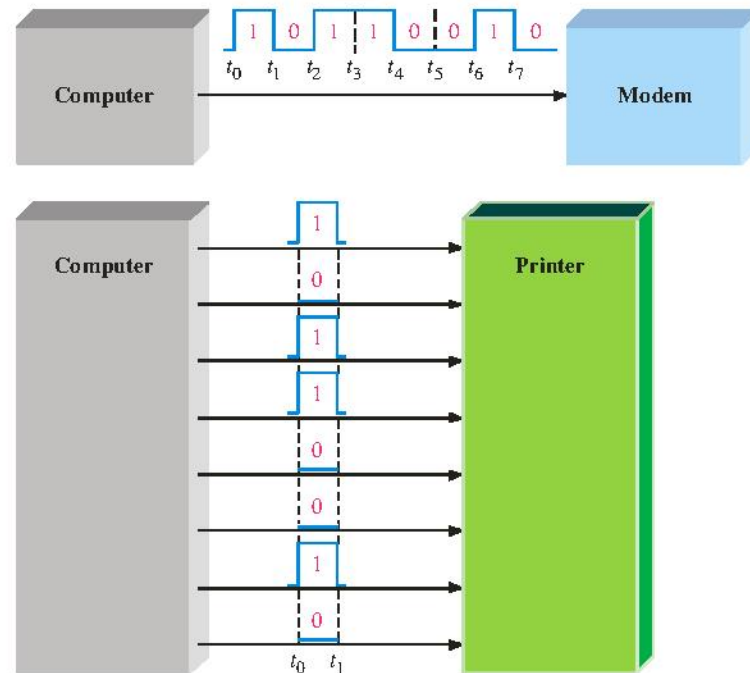

Summary

Basic Logic Functions

AND

True only if *all* input conditions are true.

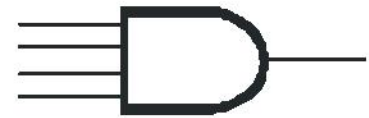

OR

True only if *one or more* input conditions are true.



NOT

Indicates the *opposite* condition.

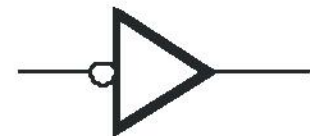
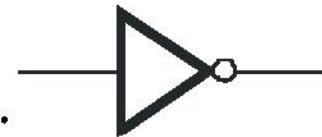

Summary

Basic System Functions

And, **or**, and **not** elements can be combined to form various logic functions. A few examples are:

The comparison function

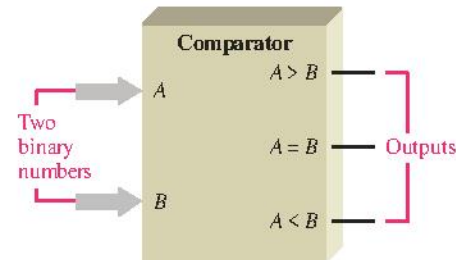

Basic arithmetic functions

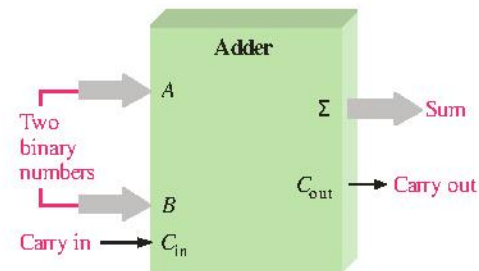

Summary

Basic System Functions

The encoding function

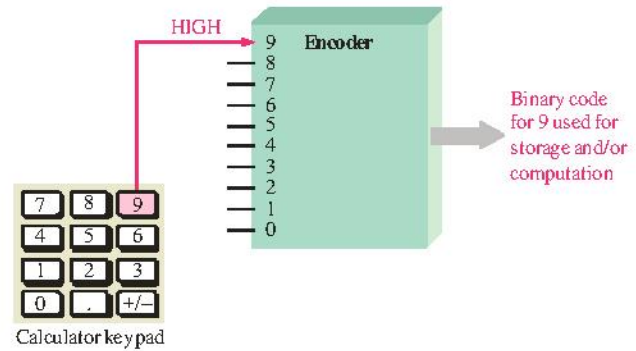

The decoding function

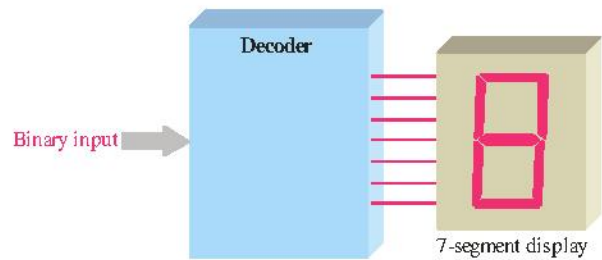

Summary

Basic System Functions

The data selection function

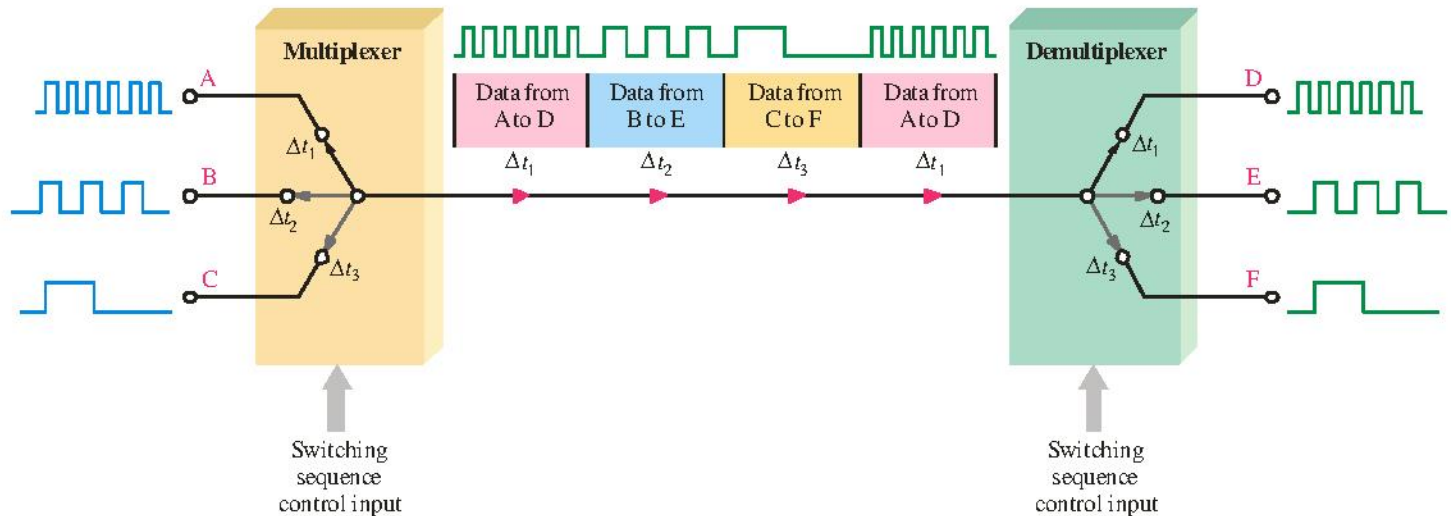

Summary

Basic System Functions

The counting function

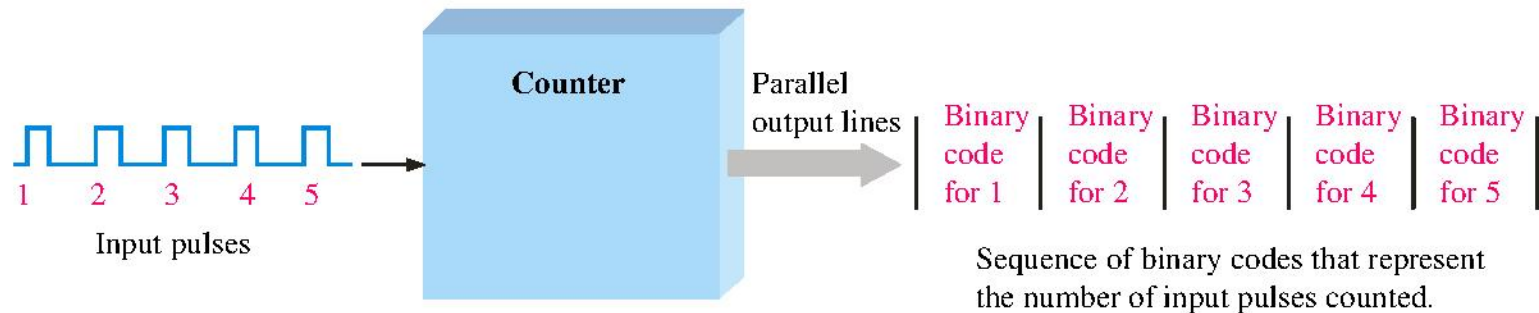

...and other functions such as code conversion and storage.

Summary

Basic System Functions

One type of storage function is the shift register, that moves and stores data each time it is clocked.

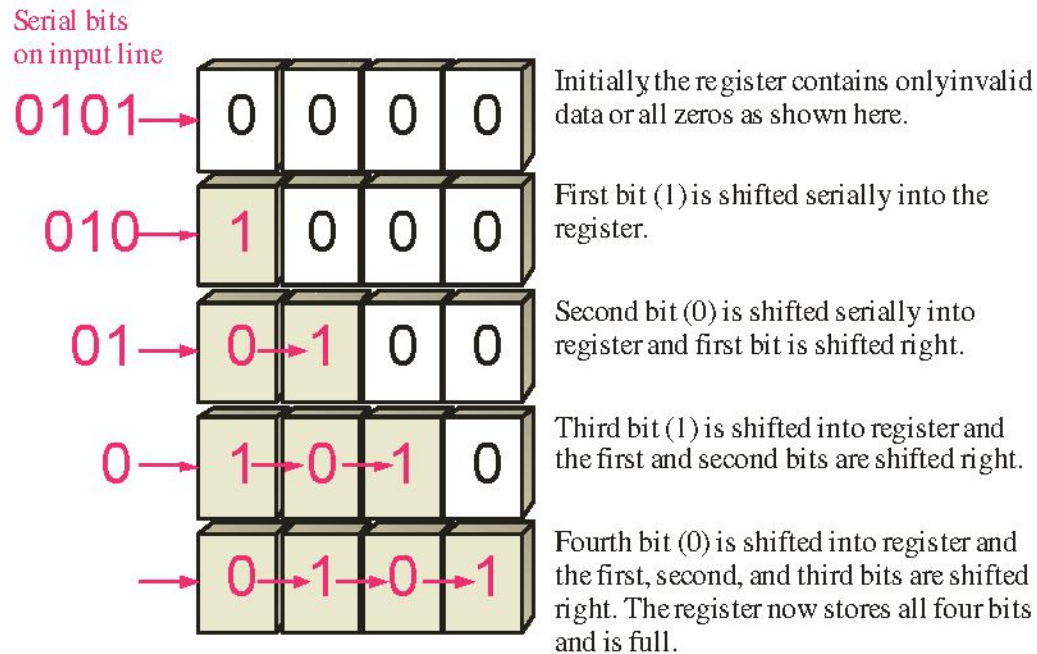

Summary

Integrated Circuits

Cutaway view of DIP (Dual-In-line Pins) chip:

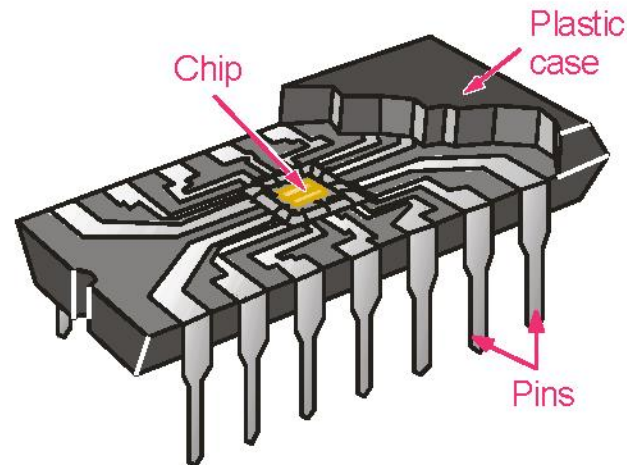

The TTL series, available as DIPs are popular for laboratory experiments with logic.

Summary

Integrated Circuits

An example of laboratory prototyping is shown. The circuit is wired using DIP chips and tested.

In this case, testing can be done by a computer connected to the system.

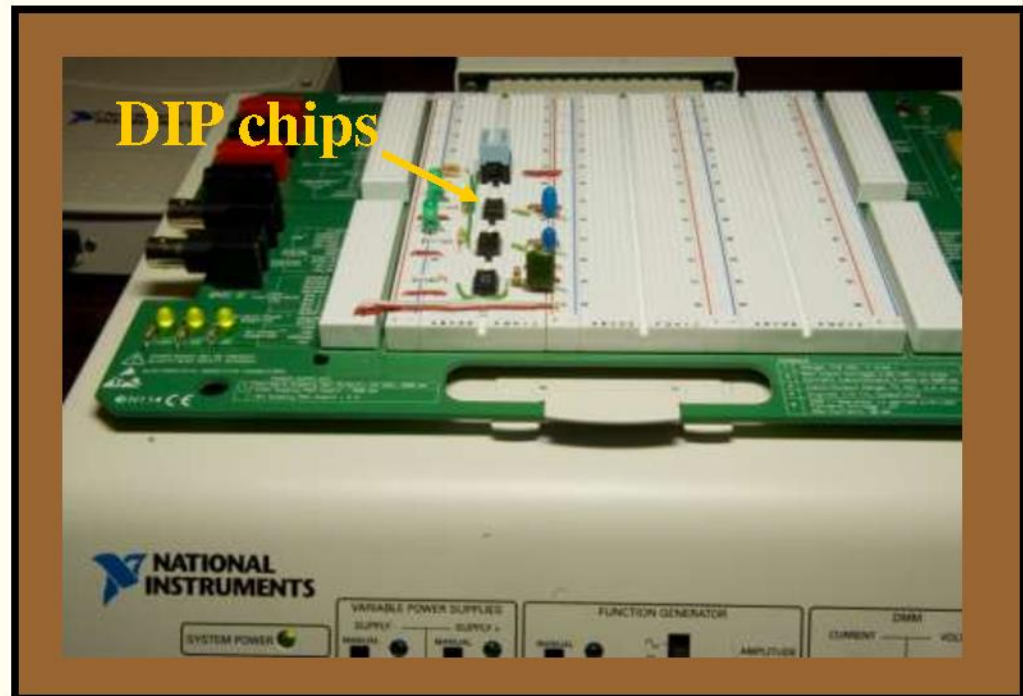

Summary

Integrated Circuits

DIP chips and surface mount chips

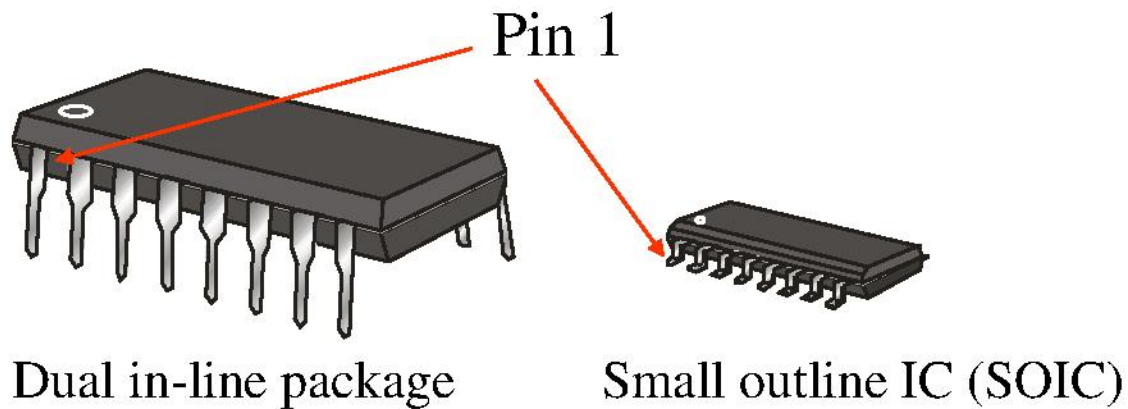

Summary

Integrated Circuits

Other surface mount packages:

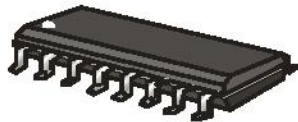

End view

SOIC

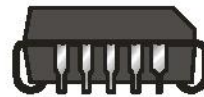
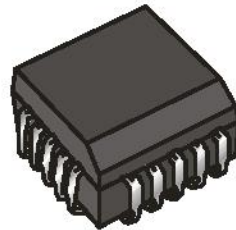

End view

PLCC



End view

LCCC

Summary

Test and Measurement Instruments

The front panel controls for a general-purpose oscilloscope can be divided into four major groups.

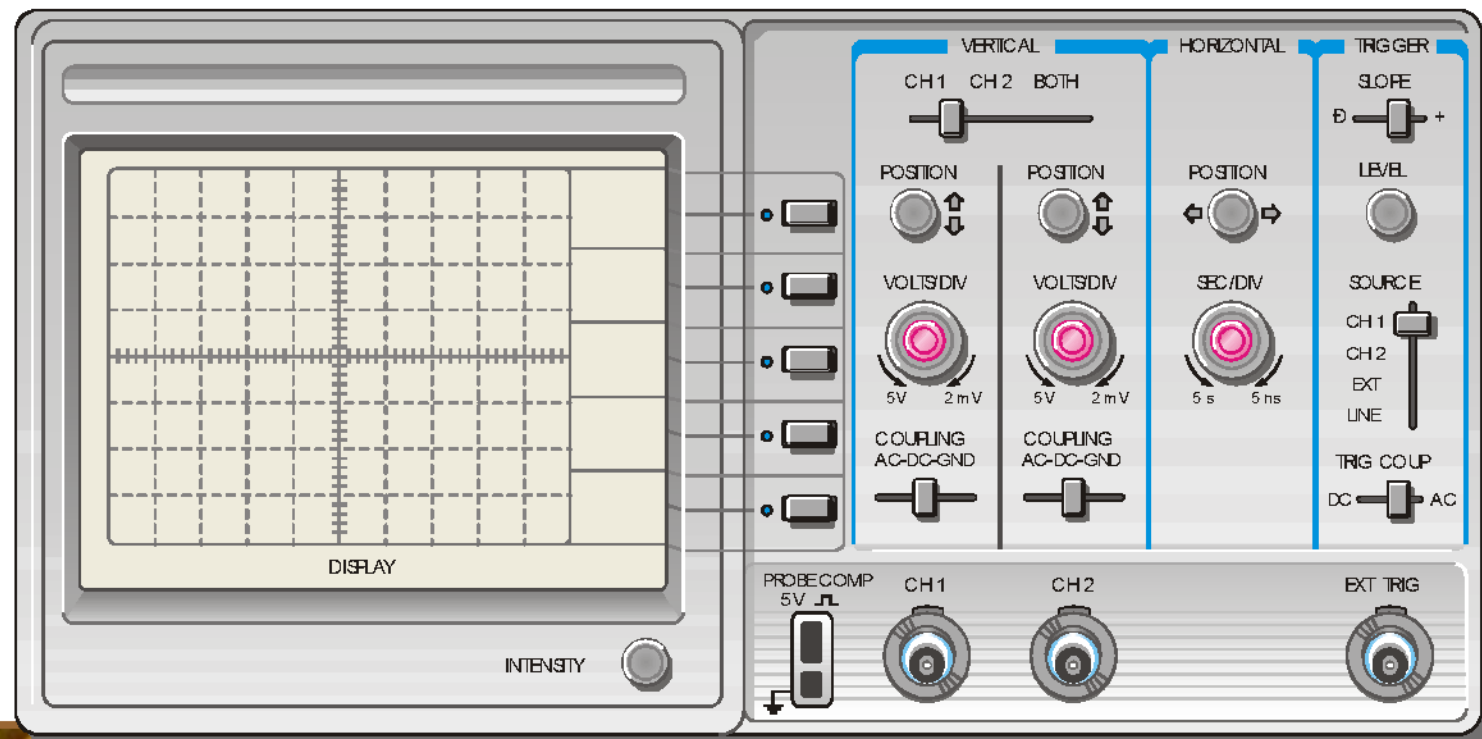

Summary

Test and Measurement Instruments

The DMM can make three basic electrical measurements.

Voltage

Resistance

Current

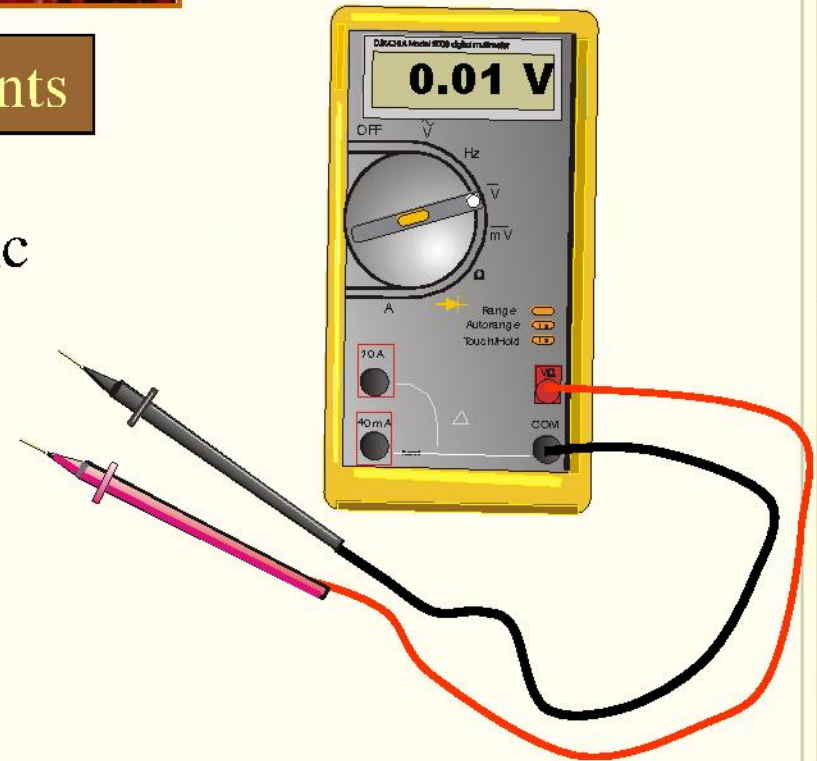

In digital work, DMMs are useful for checking power supply voltages, verifying resistors, testing continuity, and occasionally making other measurements.

Summary

Programmable Logic

Programmable logic devices (PLDs) are an alternative to fixed function devices. The logic can be programmed for a specific purpose. In general, they cost less and use less board space than fixed function devices.

A PAL device is a form of PLD that uses a combination of a programmable AND array and a fixed OR array:

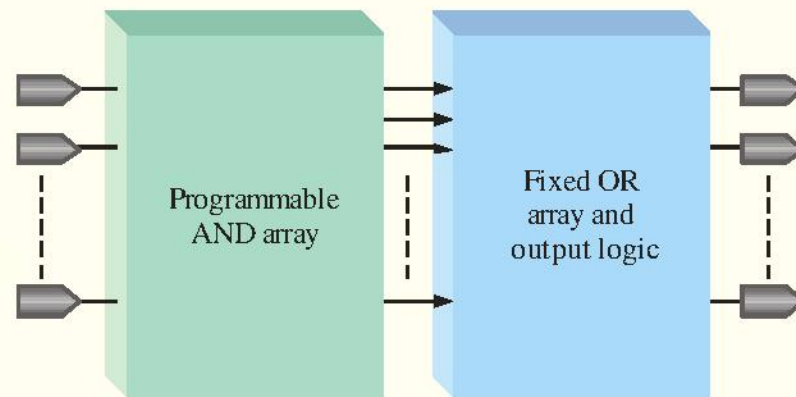

Selected Key Terms

- Analog*** Being continuous or having continuous values.
- Digital*** Related to digits or discrete quantities; having a set of discrete values.
- Binary*** Having two values or states; describes a number system that has a base of two and utilizes 1 and 0 as its digits.
- Bit*** A binary digit, which can be a 1 or a 0.
- Pulse*** A sudden change from one level to another, followed after a time, called the pulse width, by a sudden change back to the original level.

Selected Key Terms

- Clock*** A basic timing signal in a digital system; a periodic waveform used to synchronize actions.
- Gate*** A logic circuit that performs a basic logic operations such as AND or OR.
- NOT*** A basic logic function that performs inversion.
- AND*** A basic logic operation in which a true (HIGH) output occurs only when all input conditions are true (HIGH).
- OR*** A basic logic operation in which a true (HIGH) output occurs when when one or more of the input conditions are true (HIGH).

Selected Key Terms

- Fixed-function logic*** A category of digital integrated circuits having functions that cannot be altered.
- Programmable logic*** A category of digital integrated circuits capable of being programmed to perform specified functions.

Quiz

1. Compared to analog systems, digital systems
 - a. are less prone to noise
 - b. can represent an infinite number of values
 - c. can handle much higher power
 - d. all of the above

Quiz

2. The number of values that can be assigned to a bit are
- a. one
 - b. two
 - c. three
 - d. ten

Quiz

3. The time measurement between the 50% point on the leading edge of a pulse to the 50% point on the trailing edge of the pulse is called the

- a. rise time
- b. fall time
- c. period
- d. pulse width

Quiz

4. The time measurement between the 90% point on the trailing edge of a pulse to the 10% point on the trailing edge of the pulse is called the

- a. rise time
- b. fall time
- c. period
- d. pulse width

Quiz

5. The reciprocal of the frequency of a clock signal is the
- a. rise time
 - b. fall time
 - c. period
 - d. pulse width

Quiz

6. If the period of a clock signal is 500 ps, the frequency is
- a. 20 MHz
 - b. 200 MHz
 - c. 2 GHz
 - d. 20 GHz

Quiz

7. AND, OR, and NOT gates can be used to form
- a. storage devices
 - b. comparators
 - c. data selectors
 - d. all of the above

Quiz

8. A shift register is an example of a
- a. storage device
 - b. comparator
 - c. data selector
 - d. counter

Quiz

9. A device that is used to switch one of several input lines to a single output line is called a

- a. comparator
- b. decoder
- c. counter
- d. multiplexer

Quiz

10. For most digital work, an oscilloscope should be coupled to the signal using

- a. ac coupling
- b. dc coupling
- c. GND coupling
- d. none of the above

Quiz

Answers:

- | | |
|------|-------|
| 1. a | 6. c |
| 2. b | 7. d |
| 3. d | 8. a |
| 4. b | 9. d |
| 5. c | 10. b |