

Current and Resistance

- 27.1 Electric Current
- 27.2 Resistance
- 27.3 A Model for Electrical Conduction
- 27.4 Resistance and Temperature
- 27.5 Superconductors
- 27.6 Electrical Power



These two lightbulbs provide similar power output by visible light (electromagnetic radiation). The compact fluorescent bulb on the left, however, produces this light output with far less input by electrical transmission than the incandescent bulb on the right. The fluorescent bulb, therefore, is less costly to operate and saves valuable resources needed to generate electricity. (Christina Richards/Shutterstock.com)

We now consider situations involving electric charges that are in motion through some region of space. We use the term *electric current*, or simply *current*, to describe the rate of flow of charge. Most practical applications of electricity deal with electric currents, including a variety of home appliances. For example, the voltage from a wall plug produces a current in the coils of a toaster when it is turned on. In these common situations, current exists in a conductor such as a copper wire. Currents can also exist outside a conductor. For instance, a beam of electrons in a particle accelerator constitutes a current.

This chapter begins with the definition of current. A microscopic description of current is given, and some factors that contribute to the opposition to the flow of charge in conductors are discussed. A classical model is used to describe electrical conduction in metals, and some limitations of this model are cited. We also define electrical resistance and introduce a new circuit element, the resistor. We conclude by discussing the rate at which energy is transferred to a device in an electric circuit. The energy transfer mechanism in Equation 8.2 that corresponds to this process is electrical transmission T_{ET} .

27.1 Electric Current

In this section, we study the flow of electric charges through a piece of material. The amount of flow depends on both the material through which the charges are

passing and the potential difference across the material. Whenever there is a net flow of charge through some region, an electric *current* is said to exist.

It is instructive to draw an analogy between water flow and current. The flow of water in a plumbing pipe can be quantified by specifying the amount of water that emerges from a faucet during a given time interval, often measured in liters per minute. A river current can be characterized by describing the rate at which the water flows past a particular location. For example, the flow over the brink at Niagara Falls is maintained at rates between 1 400 m³/s and 2 800 m³/s.

There is also an analogy between thermal conduction and current. In Section 20.7, we discussed the flow of energy by heat through a sample of material. The rate of energy flow is determined by the material as well as the temperature difference across the material as described by Equation 20.15.

To define current quantitatively, suppose charges are moving perpendicular to a surface of area A as shown in Figure 27.1. (This area could be the cross-sectional area of a wire, for example.) The **current** is defined as the rate at which charge flows through this surface. If ΔQ is the amount of charge that passes through this surface in a time interval Δt , the **average current** I_{avg} is equal to the charge that passes through A per unit time:

$$I_{\text{avg}} = \frac{\Delta Q}{\Delta t} \quad (27.1)$$

If the rate at which charge flows varies in time, the current varies in time; we define the **instantaneous current** I as the limit of the average current as $\Delta t \rightarrow 0$:

$$I \equiv \frac{dQ}{dt} \quad (27.2)$$

The SI unit of current is the **ampere** (A):

$$1 \text{ A} = 1 \text{ C/s} \quad (27.3)$$

That is, 1 A of current is equivalent to 1 C of charge passing through a surface in 1 s.

The charged particles passing through the surface in Figure 27.1 can be positive, negative, or both. It is conventional to assign to the current the same direction as the flow of positive charge. In electrical conductors such as copper or aluminum, the current results from the motion of negatively charged electrons. Therefore, in an ordinary conductor, the direction of the current is opposite the direction of flow of electrons. For a beam of positively charged protons in an accelerator, however, the current is in the direction of motion of the protons. In some cases—such as those involving gases and electrolytes, for instance—the current is the result of the flow of both positive and negative charges. It is common to refer to a moving charge (positive or negative) as a mobile **charge carrier**.

If the ends of a conducting wire are connected to form a loop, all points on the loop are at the same electric potential; hence, the electric field is zero within and at the surface of the conductor. Because the electric field is zero, there is no net transport of charge through the wire; therefore, there is no current. If the ends of the conducting wire are connected to a battery, however, all points on the loop are not at the same potential. The battery sets up a potential difference between the ends of the loop, creating an electric field within the wire. The electric field exerts forces on the electrons in the wire, causing them to move in the wire and therefore creating a current.

Microscopic Model of Current

We can relate current to the motion of the charge carriers by describing a microscopic model of conduction in a metal. Consider the current in a cylindrical

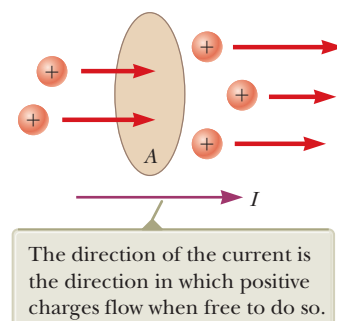

Figure 27.1 Charges in motion through an area A . The time rate at which charge flows through the area is defined as the current I .

◀ Electric current

Pitfall Prevention 27.1

"Current Flow" Is Redundant

The phrase *current flow* is commonly used, although it is technically incorrect because current is a flow (of charge). This wording is similar to the phrase *heat transfer*, which is also redundant because heat is a transfer (of energy). We will avoid this phrase and speak of *flow of charge* or *charge flow*.

Pitfall Prevention 27.2

Batteries Do Not Supply Electrons

A battery does not supply electrons to the circuit. It establishes the electric field that exerts a force on electrons already in the wires and elements of the circuit.

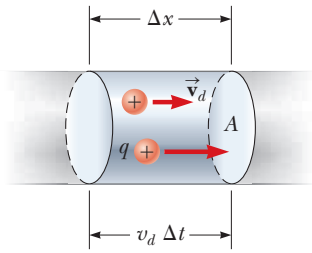
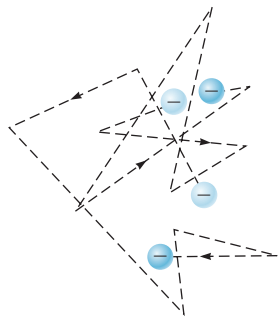

Figure 27.2 A segment of a uniform conductor of cross-sectional area A .



The random motion of the charge carriers is modified by the field, and they have a drift velocity opposite the direction of the electric field.

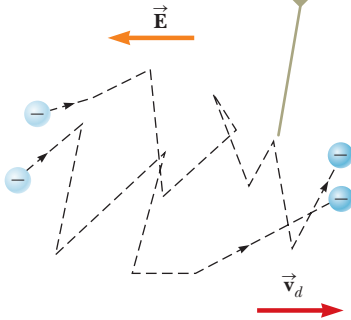

Figure 27.3 (a) A schematic diagram of the random motion of two charge carriers in a conductor in the absence of an electric field. The drift velocity is zero. (b) The motion of the charge carriers in a conductor in the presence of an electric field. Because of the acceleration of the charge carriers due to the electric force, the paths are actually parabolic. The drift speed, however, is much smaller than the average speed, so the parabolic shape is not visible on this scale.

conductor of cross-sectional area A (Fig. 27.2). The volume of a segment of the conductor of length Δx (between the two circular cross sections shown in Fig. 27.2) is $A \Delta x$. If n represents the number of mobile charge carriers per unit volume (in other words, the charge carrier density), the number of carriers in the segment is $nA \Delta x$. Therefore, the total charge ΔQ in this segment is

$$\Delta Q = (nA \Delta x)q$$

where q is the charge on each carrier. If the carriers move with a velocity \vec{v}_d parallel to the axis of the cylinder, the magnitude of the displacement they experience in the x direction in a time interval Δt is $\Delta x = v_d \Delta t$. Let Δt be the time interval required for the charge carriers in the segment to move through a displacement whose magnitude is equal to the length of the segment. This time interval is also the same as that required for all the charge carriers in the segment to pass through the circular area at one end. With this choice, we can write ΔQ as

$$\Delta Q = (nAv_d \Delta t)q$$

Dividing both sides of this equation by Δt , we find that the average current in the conductor is

$$I_{\text{avg}} = \frac{\Delta Q}{\Delta t} = nqv_d A \quad (27.4)$$

In reality, the speed of the charge carriers v_d is an average speed called the **drift speed**. To understand the meaning of drift speed, consider a conductor in which the charge carriers are free electrons. If the conductor is isolated—that is, the potential difference across it is zero—these electrons undergo random motion that is analogous to the motion of gas molecules. The electrons collide repeatedly with the metal atoms, and their resultant motion is complicated and zigzagged as in Figure 27.3a. As discussed earlier, when a potential difference is applied across the conductor (for example, by means of a battery), an electric field is set up in the conductor; this field exerts an electric force on the electrons, producing a current. In addition to the zigzag motion due to the collisions with the metal atoms, the electrons move slowly along the conductor (in a direction opposite that of \vec{E}) at the **drift velocity** \vec{v}_d as shown in Figure 27.3b.

You can think of the atom–electron collisions in a conductor as an effective internal friction (or drag force) similar to that experienced by a liquid’s molecules flowing through a pipe stuffed with steel wool. The energy transferred from the electrons to the metal atoms during collisions causes an increase in the atom’s vibrational energy and a corresponding increase in the conductor’s temperature.

Quick Quiz 27.1 Consider positive and negative charges moving horizontally through the four regions shown in Figure 27.4. Rank the current in these four regions from highest to lowest.

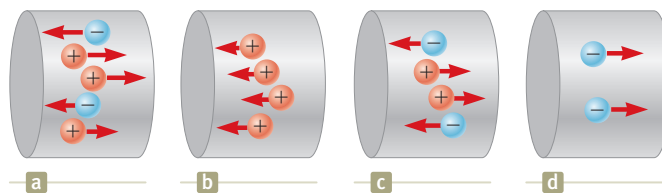

Figure 27.4 (Quick Quiz 27.1) Charges move through four regions.

Example 27.1 Drift Speed in a Copper Wire

The 12-gauge copper wire in a typical residential building has a cross-sectional area of $3.31 \times 10^{-6} \text{ m}^2$. It carries a constant current of 10.0 A. What is the drift speed of the electrons in the wire? Assume each copper atom contributes one free electron to the current. The density of copper is 8.92 g/cm^3 .

SOLUTION

Conceptualize Imagine electrons following a zigzag motion such as that in Figure 27.3a, with a drift velocity parallel to the wire superimposed on the motion as in Figure 27.3b. As mentioned earlier, the drift speed is small, and this example helps us quantify the speed.

Categorize We evaluate the drift speed using Equation 27.4. Because the current is constant, the average current during any time interval is the same as the constant current: $I_{\text{avg}} = I$.

Analyze The periodic table of the elements in Appendix C shows that the molar mass of copper is $M = 63.5 \text{ g/mol}$. Recall that 1 mol of any substance contains Avogadro's number of atoms ($N_A = 6.02 \times 10^{23} \text{ mol}^{-1}$).

Use the molar mass and the density of copper to find the volume of 1 mole of copper:

$$V = \frac{M}{\rho}$$

From the assumption that each copper atom contributes one free electron to the current, find the electron density in copper:

$$n = \frac{N_A}{V} = \frac{N_A \rho}{M}$$

Solve Equation 27.4 for the drift speed and substitute for the electron density:

$$v_d = \frac{I_{\text{avg}}}{nqA} = \frac{I}{nqA} = \frac{IM}{qAN_A\rho}$$

Substitute numerical values:

$$\begin{aligned} v_d &= \frac{(10.0 \text{ A})(0.0635 \text{ kg/mol})}{(1.60 \times 10^{-19} \text{ C})(3.31 \times 10^{-6} \text{ m}^2)(6.02 \times 10^{23} \text{ mol}^{-1})(8920 \text{ kg/m}^3)} \\ &= 2.23 \times 10^{-4} \text{ m/s} \end{aligned}$$

Finalize This result shows that typical drift speeds are very small. For instance, electrons traveling with a speed of $2.23 \times 10^{-4} \text{ m/s}$ would take about 75 min to travel 1 m! You might therefore wonder why a light turns on almost instantaneously when its switch is thrown. In a conductor, changes in the electric field that drives the free electrons according to the particle in a field model travel through the conductor with a speed close to that of light. So, when you flip on a light switch, electrons already in the filament of the lightbulb experience electric forces and begin moving after a time interval on the order of nanoseconds.

27.2 Resistance

In Section 24.4, we argued that the electric field inside a conductor is zero. This statement is true, however, *only* if the conductor is in static equilibrium as stated in that discussion. The purpose of this section is to describe what happens when there is a nonzero electric field in the conductor. As we saw in Section 27.1, a current exists in the wire in this case.

Consider a conductor of cross-sectional area A carrying a current I . The **current density** J in the conductor is defined as the current per unit area. Because the current $I = nqv_dA$, the current density is

$$J \equiv \frac{I}{A} = nqv_d \quad (27.5) \quad \leftarrow \text{Current density}$$



© Bettmann/Corbis

Georg Simon Ohm

German physicist (1789–1854)

Ohm, a high school teacher and later a professor at the University of Munich, formulated the concept of resistance and discovered the proportionalities expressed in Equations 27.6 and 27.7.

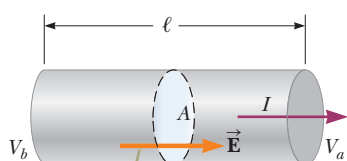

A potential difference $\Delta V = V_b - V_a$ maintained across the conductor sets up an electric field \vec{E} , and this field produces a current I that is proportional to the potential difference.

Figure 27.5 A uniform conductor of length ℓ and cross-sectional area A .

Pitfall Prevention 27.3

Equation 27.7 Is Not Ohm's Law

Many individuals call Equation 27.7 Ohm's law, but that is incorrect. This equation is simply the definition of resistance, and it provides an important relationship between voltage, current, and resistance. Ohm's law is related to a proportionality of J to E (Eq. 27.6) or, equivalently, of I to ΔV , which, from Equation 27.7, indicates that the resistance is constant, independent of the applied voltage. We will see some devices for which Equation 27.7 correctly describes their resistance, but that do *not* obey Ohm's law.

where J has SI units of amperes per meter squared. This expression is valid only if the current density is uniform and only if the surface of cross-sectional area A is perpendicular to the direction of the current.

A current density and an electric field are established in a conductor whenever a potential difference is maintained across the conductor. In some materials, the current density is proportional to the electric field:

$$J = \sigma E \quad (27.6)$$

where the constant of proportionality σ is called the **conductivity** of the conductor.¹ Materials that obey Equation 27.6 are said to follow **Ohm's law**, named after Georg Simon Ohm. More specifically, Ohm's law states the following:

For many materials (including most metals), the ratio of the current density to the electric field is a constant σ that is independent of the electric field producing the current.

Materials and devices that obey Ohm's law and hence demonstrate this simple relationship between E and J are said to be *ohmic*. Experimentally, however, it is found that not all materials and devices have this property. Those that do not obey Ohm's law are said to be *nonohmic*. Ohm's law is not a fundamental law of nature; rather, it is an empirical relationship valid only for certain situations.

We can obtain an equation useful in practical applications by considering a segment of straight wire of uniform cross-sectional area A and length ℓ as shown in Figure 27.5. A potential difference $\Delta V = V_b - V_a$ is maintained across the wire, creating in the wire an electric field and a current. If the field is assumed to be uniform, the magnitude of the potential difference across the wire is related to the field within the wire through Equation 25.6,

$$\Delta V = E\ell$$

Therefore, we can express the current density (Eq. 27.6) in the wire as

$$J = \sigma \frac{\Delta V}{\ell}$$

Because $J = I/A$, the potential difference across the wire is

$$\Delta V = \frac{\ell}{\sigma} J = \left(\frac{\ell}{\sigma A} \right) I = R I$$

The quantity $R = \ell/\sigma A$ is called the **resistance** of the conductor. We define the resistance as the ratio of the potential difference across a conductor to the current in the conductor:

$$R \equiv \frac{\Delta V}{I} \quad (27.7)$$

We will use this equation again and again when studying electric circuits. This result shows that resistance has SI units of volts per ampere. One volt per ampere is defined to be one **ohm** (Ω):

$$1 \Omega \equiv 1 \text{ V/A} \quad (27.8)$$

Equation 27.7 shows that if a potential difference of 1 V across a conductor causes a current of 1 A, the resistance of the conductor is 1 Ω . For example, if an electrical appliance connected to a 120-V source of potential difference carries a current of 6 A, its resistance is 20 Ω .

Most electric circuits use circuit elements called **resistors** to control the current in the various parts of the circuit. As with capacitors in Chapter 26, many resistors are built into integrated circuit chips, but stand-alone resistors are still available and

¹Do not confuse conductivity σ with surface charge density, for which the same symbol is used.

Table 27.1 Color Coding for Resistors

Color	Number	Multiplier	Tolerance
Black	0	1	
Brown	1	10^1	
Red	2	10^2	
Orange	3	10^3	
Yellow	4	10^4	
Green	5	10^5	
Blue	6	10^6	
Violet	7	10^7	
Gray	8	10^8	
White	9	10^9	
Gold		10^{-1}	5%
Silver		10^{-2}	10%
Colorless			20%

widely used. Two common types are the *composition resistor*, which contains carbon, and the *wire-wound resistor*, which consists of a coil of wire. Values of resistors in ohms are normally indicated by color coding as shown in Figure 27.6 and Table 27.1. The first two colors on a resistor give the first two digits in the resistance value, with the decimal place to the right of the second digit. The third color represents the power of 10 for the multiplier of the resistance value. The last color is the tolerance of the resistance value. As an example, the four colors on the resistor at the bottom of Figure 27.6 are yellow (= 4), violet (= 7), black (= 10^0), and gold (= 5%), and so the resistance value is $47 \times 10^0 = 47 \Omega$ with a tolerance value of $5\% = 2 \Omega$.

The inverse of conductivity is **resistivity**² ρ :

$$\rho = \frac{1}{\sigma} \quad (27.9)$$

where ρ has the units ohm \cdot meters ($\Omega \cdot \text{m}$). Because $R = \ell/\sigma A$, we can express the resistance of a uniform block of material along the length ℓ as

$$R = \rho \frac{\ell}{A} \quad (27.10)$$

Every ohmic material has a characteristic resistivity that depends on the properties of the material and on temperature. In addition, as you can see from Equation 27.10, the resistance of a sample of the material depends on the geometry of the sample as well as on the resistivity of the material. Table 27.2 (page 814) gives the resistivities of a variety of materials at 20°C . Notice the enormous range, from very low values for good conductors such as copper and silver to very high values for good insulators such as glass and rubber. An ideal conductor would have zero resistivity, and an ideal insulator would have infinite resistivity.

Equation 27.10 shows that the resistance of a given cylindrical conductor such as a wire is proportional to its length and inversely proportional to its cross-sectional area. If the length of a wire is doubled, its resistance doubles. If its cross-sectional area is doubled, its resistance decreases by one half. The situation is analogous to the flow of a liquid through a pipe. As the pipe's length is increased, the resistance to flow increases. As the pipe's cross-sectional area is increased, more liquid crosses a given cross section of the pipe per unit time interval. Therefore, more liquid flows for the same pressure differential applied to the pipe, and the resistance to flow decreases.

Ohmic materials and devices have a linear current–potential difference relationship over a broad range of applied potential differences (Fig. 27.7a, page 814). The slope of the I -versus- ΔV curve in the linear region yields a value for $1/R$. Nonohmic

The colored bands on this resistor are yellow, violet, black, and gold.

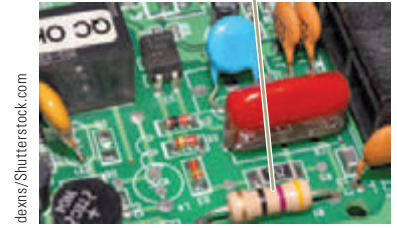

Figure 27.6 A close-up view of a circuit board shows the color coding on a resistor. The gold band on the left tells us that the resistor is oriented “backward” in this view and we need to read the colors from right to left.

◀ Resistivity is the inverse of conductivity

◀ Resistance of a uniform material along the length ℓ

Pitfall Prevention 27.4

Resistance and Resistivity Resistivity is a property of a *substance*, whereas resistance is a property of an *object*. We have seen similar pairs of variables before. For example, density is a property of a substance, whereas mass is a property of an object. Equation 27.10 relates resistance to resistivity, and Equation 1.1 relates mass to density.

²Do not confuse resistivity ρ with mass density or charge density, for which the same symbol is used.

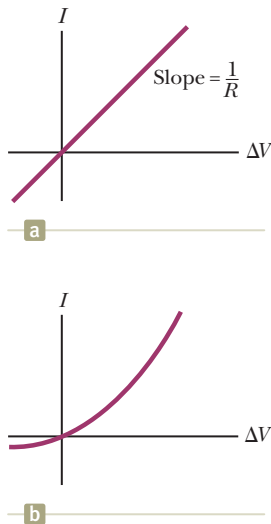

Figure 27.7 (a) The current–potential difference curve for an ohmic material. The curve is linear, and the slope is equal to the inverse of the resistance of the conductor. (b) A nonlinear current–potential difference curve for a junction diode. This device does not obey Ohm’s law.

Table 27.2 Resistivities and Temperature Coefficients of Resistivity for Various Materials

Material	Resistivity ^a ($\Omega \cdot \text{m}$)	Temperature Coefficient ^b α [$(^\circ\text{C})^{-1}$]
Silver	1.59×10^{-8}	3.8×10^{-3}
Copper	1.7×10^{-8}	3.9×10^{-3}
Gold	2.44×10^{-8}	3.4×10^{-3}
Aluminum	2.82×10^{-8}	3.9×10^{-3}
Tungsten	5.6×10^{-8}	4.5×10^{-3}
Iron	10×10^{-8}	5.0×10^{-3}
Platinum	11×10^{-8}	3.92×10^{-3}
Lead	22×10^{-8}	3.9×10^{-3}
Nichrome ^c	1.00×10^{-6}	0.4×10^{-3}
Carbon	3.5×10^{-5}	-0.5×10^{-3}
Germanium	0.46	-48×10^{-3}
Silicon ^d	2.3×10^3	-75×10^{-3}
Glass	10^{10} to 10^{14}	
Hard rubber	$\sim 10^{13}$	
Sulfur	10^{15}	
Quartz (fused)	75×10^{16}	

^a All values at 20°C . All elements in this table are assumed to be free of impurities.

^b See Section 27.4.

^c A nickel–chromium alloy commonly used in heating elements. The resistivity of Nichrome varies with composition and ranges between 1.00×10^{-6} and $1.50 \times 10^{-6} \Omega \cdot \text{m}$.

^d The resistivity of silicon is very sensitive to purity. The value can be changed by several orders of magnitude when it is doped with other atoms.

materials have a nonlinear current–potential difference relationship. One common semiconducting device with nonlinear I -versus- ΔV characteristics is the *junction diode* (Fig. 27.7b). The resistance of this device is low for currents in one direction (positive ΔV) and high for currents in the reverse direction (negative ΔV). In fact, most modern electronic devices, such as transistors, have nonlinear current–potential difference relationships; their proper operation depends on the particular way they violate Ohm’s law.

Quick Quiz 27.2 A cylindrical wire has a radius r and length ℓ . If both r and ℓ are doubled, does the resistance of the wire (a) increase, (b) decrease, or (c) remain the same?

Quick Quiz 27.3 In Figure 27.7b, as the applied voltage increases, does the resistance of the diode (a) increase, (b) decrease, or (c) remain the same?

Example 27.2 The Resistance of Nichrome Wire

The radius of 22-gauge Nichrome wire is 0.32 mm.

(A) Calculate the resistance per unit length of this wire.

SOLUTION

Conceptualize Table 27.2 shows that Nichrome has a resistivity two orders of magnitude larger than the best conductors in the table. Therefore, we expect it to have some special practical applications that the best conductors may not have.

Categorize We model the wire as a cylinder so that a simple geometric analysis can be applied to find the resistance.

Analyze Use Equation 27.10 and the resistivity of Nichrome from Table 27.2 to find the resistance per unit length:

$$\frac{R}{\ell} = \frac{\rho}{A} = \frac{\rho}{\pi r^2} = \frac{1.0 \times 10^{-6} \Omega \cdot \text{m}}{\pi(0.32 \times 10^{-3} \text{ m})^2} = 3.1 \Omega/\text{m}$$

► 27.2 continued

(B) If a potential difference of 10 V is maintained across a 1.0-m length of the Nichrome wire, what is the current in the wire?

SOLUTION

Analyze Use Equation 27.7 to find the current:

$$I = \frac{\Delta V}{R} = \frac{\Delta V}{(R/\ell)\ell} = \frac{10 \text{ V}}{(3.1 \Omega/\text{m})(1.0 \text{ m})} = 3.2 \text{ A}$$

Finalize Because of its high resistivity and resistance to oxidation, Nichrome is often used for heating elements in toasters, irons, and electric heaters.

WHAT IF? What if the wire were composed of copper instead of Nichrome? How would the values of the resistance per unit length and the current change?

Answer Table 27.2 shows us that copper has a resistivity two orders of magnitude smaller than that for Nichrome. Therefore, we expect the answer to part (A) to be smaller and the answer to part (B) to be larger. Calculations show that a copper wire of the same radius would have a resistance per unit length of only $0.053 \Omega/\text{m}$. A 1.0-m length of copper wire of the same radius would carry a current of 190 A with an applied potential difference of 10 V.

Example 27.3 The Radial Resistance of a Coaxial Cable

Coaxial cables are used extensively for cable television and other electronic applications. A coaxial cable consists of two concentric cylindrical conductors. The region between the conductors is completely filled with polyethylene plastic as shown in Figure 27.8a. Current leakage through the plastic, in the *radial* direction, is unwanted. (The cable is designed to conduct current along its length, but that is *not* the current being considered here.) The radius of the inner conductor is $a = 0.500 \text{ cm}$, the radius of the outer conductor is $b = 1.75 \text{ cm}$, and the length is $L = 15.0 \text{ cm}$. The resistivity of the plastic is $1.0 \times 10^{13} \Omega \cdot \text{m}$. Calculate the resistance of the plastic between the two conductors.

SOLUTION

Conceptualize Imagine two currents as suggested in the text of the problem. The desired current is along the cable, carried within the conductors. The undesired current corresponds to leakage through the plastic, and its direction is radial.

Categorize Because the resistivity and the geometry of the plastic are known, we categorize this problem as one in which we find the resistance of the plastic from these parameters. Equation 27.10, however, represents the resistance of a block of material. We have a more complicated geometry in this situation. Because the area through which the charges pass depends on the radial position, we must use integral calculus to determine the answer.

Analyze We divide the plastic into concentric cylindrical shells of infinitesimal thickness dr (Fig. 27.8b). Any charge passing from the inner to the outer conductor must move radially through this shell. Use a differential form of Equation 27.10, replacing ℓ with dr for the length variable: $dR = \rho dr/A$, where dR is the resistance of a shell of plastic of thickness dr and surface area A .

Write an expression for the resistance of our hollow cylindrical shell of plastic representing the area as the surface area of the shell:

$$dR = \frac{\rho dr}{A} = \frac{\rho}{2\pi rL} dr$$

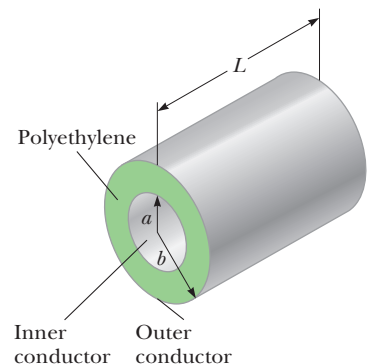

a

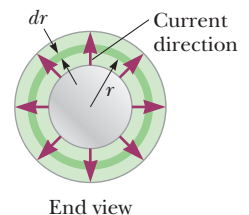

b

Figure 27.8 (Example 27.3) A coaxial cable. (a) Polyethylene plastic fills the gap between the two conductors. (b) End view, showing current leakage.

continued

▶ 27.3 continued

Integrate this expression from $r = a$ to $r = b$:

$$(1) \quad R = \int dR = \frac{\rho}{2\pi L} \int_a^b \frac{dr}{r} = \frac{\rho}{2\pi L} \ln\left(\frac{b}{a}\right)$$

Substitute the values given:

$$R = \frac{1.0 \times 10^{13} \Omega \cdot \text{m}}{2\pi(0.150 \text{ m})} \ln\left(\frac{1.75 \text{ cm}}{0.500 \text{ cm}}\right) = 1.33 \times 10^{13} \Omega$$

Finalize Let's compare this resistance to that of the inner copper conductor of the cable along the 15.0-cm length.

Use Equation 27.10 to find the resistance of the copper cylinder:

$$\begin{aligned} R_{\text{Cu}} &= \rho \frac{\ell}{A} = (1.7 \times 10^{-8} \Omega \cdot \text{m}) \left[\frac{0.150 \text{ m}}{\pi(5.00 \times 10^{-3} \text{ m})^2} \right] \\ &= 3.2 \times 10^{-5} \Omega \end{aligned}$$

This resistance is 18 orders of magnitude smaller than the radial resistance. Therefore, almost all the current corresponds to charge moving along the length of the cable, with a very small fraction leaking in the radial direction.

WHAT IF? Suppose the coaxial cable is enlarged to twice the overall diameter with two possible choices: (1) the ratio b/a is held fixed, or (2) the difference $b - a$ is held fixed. For which choice does the leakage current between the inner and outer conductors increase when the voltage is applied between them?

Answer For the current to increase, the resistance must decrease. For choice (1), in which b/a is held fixed, Equa-

tion (1) shows that the resistance is unaffected. For choice (2), we do not have an equation involving the difference $b - a$ to inspect. Looking at Figure 27.8b, however, we see that increasing b and a while holding the difference constant results in charge flowing through the same thickness of plastic but through a larger area perpendicular to the flow. This larger area results in lower resistance and a higher current.

27.3 A Model for Electrical Conduction

In this section, we describe a structural model of electrical conduction in metals that was first proposed by Paul Drude (1863–1906) in 1900. (See Section 21.1 for a review of structural models.) This model leads to Ohm's law and shows that resistivity can be related to the motion of electrons in metals. Although the Drude model described here has limitations, it introduces concepts that are applied in more elaborate treatments.

Following the outline of structural models from Section 21.1, the Drude model for electrical conduction has the following properties:

1. *Physical components:*

Consider a conductor as a regular array of atoms plus a collection of free electrons, which are sometimes called *conduction* electrons. We identify the system as the combination of the atoms and the conduction electrons. The conduction electrons, although bound to their respective atoms when the atoms are not part of a solid, become free when the atoms condense into a solid.

2. *Behavior of the components:*

- In the absence of an electric field, the conduction electrons move in random directions through the conductor (Fig. 27.3a). The situation is similar to the motion of gas molecules confined in a vessel. In fact, some scientists refer to conduction electrons in a metal as an *electron gas*.
- When an electric field is applied to the system, the free electrons drift slowly in a direction opposite that of the electric field (Fig. 27.3b), with an average drift speed v_d that is much smaller (typically 10^{-4} m/s) than their average speed v_{avg} between collisions (typically 10^6 m/s).
- The electron's motion after a collision is independent of its motion before the collision. The excess energy acquired by the electrons due to

the work done on them by the electric field is transferred to the atoms of the conductor when the electrons and atoms collide.

With regard to property 2(c) above, the energy transferred to the atoms causes the internal energy of the system and, therefore, the temperature of the conductor to increase.

We are now in a position to derive an expression for the drift velocity, using several of our analysis models. When a free electron of mass m_e and charge q ($= -e$) is subjected to an electric field $\vec{\mathbf{E}}$, it is described by the particle in a field model and experiences a force $\vec{\mathbf{F}} = q\vec{\mathbf{E}}$. The electron is a particle under a net force, and its acceleration can be found from Newton's second law, $\Sigma \vec{\mathbf{F}} = m\vec{\mathbf{a}}$:

$$\vec{\mathbf{a}} = \frac{\Sigma \vec{\mathbf{F}}}{m} = \frac{q\vec{\mathbf{E}}}{m_e} \quad (27.11)$$

Because the electric field is uniform, the electron's acceleration is constant, so the electron can be modeled as a particle under constant acceleration. If $\vec{\mathbf{v}}_i$ is the electron's initial velocity the instant after a collision (which occurs at a time defined as $t = 0$), the velocity of the electron at a very short time t later (immediately before the next collision occurs) is, from Equation 4.8,

$$\vec{\mathbf{v}}_f = \vec{\mathbf{v}}_i + \vec{\mathbf{a}}t = \vec{\mathbf{v}}_i + \frac{q\vec{\mathbf{E}}}{m_e} t \quad (27.12)$$

Let's now take the average value of $\vec{\mathbf{v}}_f$ for all the electrons in the wire over all possible collision times t and all possible values of $\vec{\mathbf{v}}_i$. Assuming the initial velocities are randomly distributed over all possible directions (property 2(a) above), the average value of $\vec{\mathbf{v}}_i$ is zero. The average value of the second term of Equation 27.12 is $(q\vec{\mathbf{E}}/m_e)\tau$, where τ is the *average time interval between successive collisions*. Because the average value of $\vec{\mathbf{v}}_f$ is equal to the drift velocity,

$$\vec{\mathbf{v}}_{f,\text{avg}} = \vec{\mathbf{v}}_d = \frac{q\vec{\mathbf{E}}}{m_e} \tau \quad (27.13)$$

◀ Drift velocity in terms of microscopic quantities

The value of τ depends on the size of the metal atoms and the number of electrons per unit volume. We can relate this expression for drift velocity in Equation 27.13 to the current in the conductor. Substituting the magnitude of the velocity from Equation 27.13 into Equation 27.4, the average current in the conductor is given by

$$I_{\text{avg}} = nq \left(\frac{qE}{m_e} \tau \right) A = \frac{nq^2 E}{m_e} \tau A \quad (27.14)$$

Because the current density J is the current divided by the area A ,

$$J = \frac{nq^2 E}{m_e} \tau$$

◀ Current density in terms of microscopic quantities

where n is the number of electrons per unit volume. Comparing this expression with Ohm's law, $J = \sigma E$, we obtain the following relationships for conductivity and resistivity of a conductor:

$$\sigma = \frac{nq^2 \tau}{m_e} \quad (27.15)$$

◀ Conductivity in terms of microscopic quantities

$$\rho = \frac{1}{\sigma} = \frac{m_e}{nq^2 \tau} \quad (27.16)$$

◀ Resistivity in terms of microscopic quantities

According to this classical model, conductivity and resistivity do not depend on the strength of the electric field. This feature is characteristic of a conductor obeying Ohm's law.

The model shows that the resistivity can be calculated from a knowledge of the density of the electrons, their charge and mass, and the average time interval τ between collisions. This time interval is related to the average distance between collisions ℓ_{avg} (the *mean free path*) and the average speed v_{avg} through the expression³

$$\tau = \frac{\ell_{\text{avg}}}{v_{\text{avg}}} \quad (27.17)$$

Although this structural model of conduction is consistent with Ohm's law, it does not correctly predict the values of resistivity or the behavior of the resistivity with temperature. For example, the results of classical calculations for v_{avg} using the ideal gas model for the electrons are about a factor of ten smaller than the actual values, which results in incorrect predictions of values of resistivity from Equation 27.16. Furthermore, according to Equations 27.16 and 27.17, the resistivity is predicted to vary with temperature as does v_{avg} , which, according to an ideal-gas model (Chapter 21, Eq. 21.43), is proportional to \sqrt{T} . This behavior is in disagreement with the experimentally observed linear dependence of resistivity with temperature for pure metals. (See Section 27.4.) Because of these incorrect predictions, we must modify our structural model. We shall call the model that we have developed so far the *classical* model for electrical conduction. To account for the incorrect predictions of the classical model, we develop it further into a *quantum mechanical* model, which we shall describe briefly.

We discussed two important simplification models in earlier chapters, the particle model and the wave model. Although we discussed these two simplification models separately, quantum physics tells us that this separation is not so clear-cut. As we shall discuss in detail in Chapter 40, particles have wave-like properties. The predictions of some models can only be matched to experimental results if the model includes the wave-like behavior of particles. The structural model for electrical conduction in metals is one of these cases.

Let us imagine that the electrons moving through the metal have wave-like properties. If the array of atoms in a conductor is regularly spaced (that is, periodic), the wave-like character of the electrons makes it possible for them to move freely through the conductor and a collision with an atom is unlikely. For an idealized conductor, no collisions would occur, the mean free path would be infinite, and the resistivity would be zero. Electrons are scattered only if the atomic arrangement is irregular (not periodic), as a result of structural defects or impurities, for example. At low temperatures, the resistivity of metals is dominated by scattering caused by collisions between the electrons and impurities. At high temperatures, the resistivity is dominated by scattering caused by collisions between the electrons and the atoms of the conductor, which are continuously displaced as a result of thermal agitation, destroying the perfect periodicity. The thermal motion of the atoms makes the structure irregular (compared with an atomic array at rest), thereby reducing the electron's mean free path.

Although it is beyond the scope of this text to show this modification in detail, the classical model modified with the wave-like character of the electrons results in predictions of resistivity values that are in agreement with measured values and predicts a linear temperature dependence. Quantum notions had to be introduced in Chapter 21 to understand the temperature behavior of molar specific heats of gases. Here we have another case in which quantum physics is necessary for the model to agree with experiment. Although classical physics can explain a tremendous range of phenomena, we continue to see hints that quantum physics must be incorporated into our models. We shall study quantum physics in detail in Chapters 40 through 46.

³Recall that the average speed of a group of particles depends on the temperature of the group (Chapter 21) and is not the same as the drift speed v_d .

27.4 Resistance and Temperature

Over a limited temperature range, the resistivity of a conductor varies approximately linearly with temperature according to the expression

$$\rho = \rho_0[1 + \alpha(T - T_0)] \quad (27.18)$$

where ρ is the resistivity at some temperature T (in degrees Celsius), ρ_0 is the resistivity at some reference temperature T_0 (usually taken to be 20°C), and α is the **temperature coefficient of resistivity**. From Equation 27.18, the temperature coefficient of resistivity can be expressed as

$$\alpha = \frac{1}{\rho_0} \frac{\Delta\rho}{\Delta T} \quad (27.19)$$

where $\Delta\rho = \rho - \rho_0$ is the change in resistivity in the temperature interval $\Delta T = T - T_0$.

The temperature coefficients of resistivity for various materials are given in Table 27.2. Notice that the unit for α is degrees Celsius⁻¹ [$(^\circ\text{C})^{-1}$]. Because resistance is proportional to resistivity (Eq. 27.10), the variation of resistance of a sample is

$$R = R_0[1 + \alpha(T - T_0)] \quad (27.20)$$

where R_0 is the resistance at temperature T_0 . Use of this property enables precise temperature measurements through careful monitoring of the resistance of a probe made from a particular material.

For some metals such as copper, resistivity is nearly proportional to temperature as shown in Figure 27.9. A nonlinear region always exists at very low temperatures, however, and the resistivity usually reaches some finite value as the temperature approaches absolute zero. This residual resistivity near absolute zero is caused primarily by the collision of electrons with impurities and imperfections in the metal. In contrast, high-temperature resistivity (the linear region) is predominantly characterized by collisions between electrons and metal atoms.

Notice that three of the α values in Table 27.2 are negative, indicating that the resistivity of these materials decreases with increasing temperature. This behavior is indicative of a class of materials called *semiconductors*, first introduced in Section 23.2, and is due to an increase in the density of charge carriers at higher temperatures.

Because the charge carriers in a semiconductor are often associated with impurity atoms (as we discuss in more detail in Chapter 43), the resistivity of these materials is very sensitive to the type and concentration of such impurities.

Quick Quiz 27.4 When does an incandescent lightbulb carry more current, (a) immediately after it is turned on and the glow of the metal filament is increasing or (b) after it has been on for a few milliseconds and the glow is steady?

27.5 Superconductors

There is a class of metals and compounds whose resistance decreases to zero when they are below a certain temperature T_c , known as the **critical temperature**. These materials are known as **superconductors**. The resistance–temperature graph for a superconductor follows that of a normal metal at temperatures above T_c (Fig. 27.10). When the temperature is at or below T_c , the resistivity drops suddenly to zero. This phenomenon was discovered in 1911 by Dutch physicist Heike Kamerlingh-Onnes (1853–1926) as he worked with mercury, which is a superconductor below 4.2 K. Measurements have shown that the resistivities of superconductors below their T_c values are less than $4 \times 10^{-25} \Omega \cdot \text{m}$, or approximately 10^{17} times smaller than the resistivity of copper. In practice, these resistivities are considered to be zero.

◀ Variation of ρ with temperature

◀ Temperature coefficient of resistivity

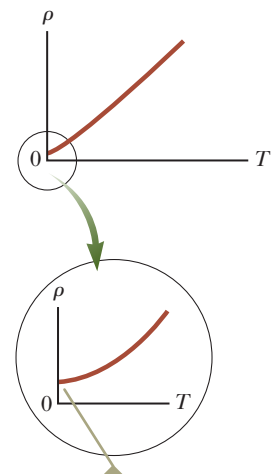

As T approaches absolute zero, the resistivity approaches a nonzero value.

Figure 27.9 Resistivity versus temperature for a metal such as copper. The curve is linear over a wide range of temperatures, and ρ increases with increasing temperature.

The resistance drops discontinuously to zero at T_c , which is 4.15 K for mercury.

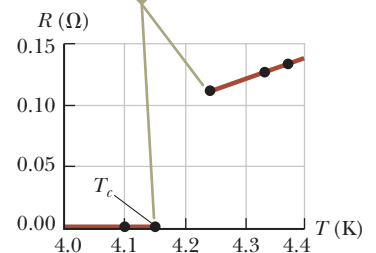

Figure 27.10 Resistance versus temperature for a sample of mercury (Hg). The graph follows that of a normal metal above the critical temperature T_c .



Courtesy of IBM Research Laboratory

A small permanent magnet levitated above a disk of the superconductor $\text{YBa}_2\text{Cu}_3\text{O}_7$, which is in liquid nitrogen at 77 K.

Table 27.3 Critical Temperatures for Various Superconductors

Material	T_c (K)
$\text{HgBa}_2\text{Ca}_2\text{Cu}_3\text{O}_8$	134
Tl—Ba—Ca—Cu—O	125
Bi—Sr—Ca—Cu—O	105
$\text{YBa}_2\text{Cu}_3\text{O}_7$	92
Nb_3Ge	23.2
Nb_3Sn	18.05
Nb	9.46
Pb	7.18
Hg	4.15
Sn	3.72
Al	1.19
Zn	0.88

Today, thousands of superconductors are known, and as Table 27.3 illustrates, the critical temperatures of recently discovered superconductors are substantially higher than initially thought possible. Two kinds of superconductors are recognized. The more recently identified ones are essentially ceramics with high critical temperatures, whereas superconducting materials such as those observed by Kamerlingh-Onnes are metals. If a room-temperature superconductor is ever identified, its effect on technology could be tremendous.

The value of T_c is sensitive to chemical composition, pressure, and molecular structure. Copper, silver, and gold, which are excellent conductors, do not exhibit superconductivity.

One truly remarkable feature of superconductors is that once a current is set up in them, it persists *without any applied potential difference* (because $R = 0$). Steady currents have been observed to persist in superconducting loops for several years with no apparent decay!

An important and useful application of superconductivity is in the development of superconducting magnets, in which the magnitudes of the magnetic field are approximately ten times greater than those produced by the best normal electromagnets. Such superconducting magnets are being considered as a means of storing energy. Superconducting magnets are currently used in medical magnetic resonance imaging, or MRI, units, which produce high-quality images of internal organs without the need for excessive exposure of patients to x-rays or other harmful radiation.

27.6 Electrical Power

In typical electric circuits, energy T_{ET} is transferred by electrical transmission from a source such as a battery to some device such as a lightbulb or a radio receiver. Let's determine an expression that will allow us to calculate the rate of this energy transfer. First, consider the simple circuit in Figure 27.11, where energy is delivered to a resistor. (Resistors are designated by the circuit symbol $\text{---}\text{---}\text{---}$.) Because the connecting wires also have resistance, some energy is delivered to the wires and some to the resistor. Unless noted otherwise, we shall assume the resistance of the wires is small compared with the resistance of the circuit element so that the energy delivered to the wires is negligible.

Imagine following a positive quantity of charge Q moving clockwise around the circuit in Figure 27.11 from point a through the battery and resistor back to point a . We identify the entire circuit as our system. As the charge moves from a to b through the battery, the electric potential energy of the system *increases* by an amount $Q\Delta V$

The direction of the effective flow of positive charge is clockwise.

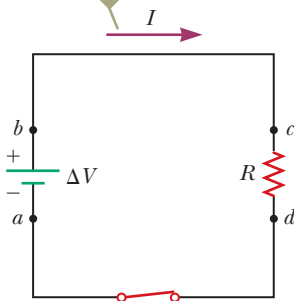

Figure 27.11 A circuit consisting of a resistor of resistance R and a battery having a potential difference ΔV across its terminals.

while the chemical potential energy in the battery *decreases* by the same amount. (Recall from Eq. 25.3 that $\Delta U = q\Delta V$.) As the charge moves from *c* to *d* through the resistor, however, the electric potential energy of the system decreases due to collisions of electrons with atoms in the resistor. In this process, the electric potential energy is transformed to internal energy corresponding to increased vibrational motion of the atoms in the resistor. Because the resistance of the interconnecting wires is neglected, no energy transformation occurs for paths *bc* and *da*. When the charge returns to point *a*, the net result is that some of the chemical potential energy in the battery has been delivered to the resistor and resides in the resistor as internal energy E_{int} associated with molecular vibration.

The resistor is normally in contact with air, so its increased temperature results in a transfer of energy by heat Q into the air. In addition, the resistor emits thermal radiation T_{ER} , representing another means of escape for the energy. After some time interval has passed, the resistor reaches a constant temperature. At this time, the input of energy from the battery is balanced by the output of energy from the resistor by heat and radiation, and the resistor is a nonisolated system in steady state. Some electrical devices include *heat sinks*⁴ connected to parts of the circuit to prevent these parts from reaching dangerously high temperatures. Heat sinks are pieces of metal with many fins. Because the metal's high thermal conductivity provides a rapid transfer of energy by heat away from the hot component and the large number of fins provides a large surface area in contact with the air, energy can transfer by radiation and into the air by heat at a high rate.

Let's now investigate the rate at which the electric potential energy of the system decreases as the charge Q passes through the resistor:

$$\frac{dU}{dt} = \frac{d}{dt}(Q\Delta V) = \frac{dQ}{dt}\Delta V = I\Delta V$$

where I is the current in the circuit. The system regains this potential energy when the charge passes through the battery, at the expense of chemical energy in the battery. The rate at which the potential energy of the system decreases as the charge passes through the resistor is equal to the rate at which the system gains internal energy in the resistor. Therefore, the power P , representing the rate at which energy is delivered to the resistor, is

$$P = I\Delta V \quad (27.21)$$

We derived this result by considering a battery delivering energy to a resistor. Equation 27.21, however, can be used to calculate the power delivered by a voltage source to *any* device carrying a current I and having a potential difference ΔV between its terminals.

Using Equation 27.21 and $\Delta V = IR$ for a resistor, we can express the power delivered to the resistor in the alternative forms

$$P = I^2R = \frac{(\Delta V)^2}{R} \quad (27.22)$$

When I is expressed in amperes, ΔV in volts, and R in ohms, the SI unit of power is the watt, as it was in Chapter 8 in our discussion of mechanical power. The process by which energy is transformed to internal energy in a conductor of resistance R is often called *joule heating*;⁵ this transformation is also often referred to as an I^2R loss.

Pitfall Prevention 27.5

Charges Do Not Move All the Way Around a Circuit in a Short Time

In terms of understanding the energy transfer in a circuit, it is useful to *imagine* a charge moving all the way around the circuit even though it would take hours to do so.

Pitfall Prevention 27.6

Misconceptions About Current

Several common misconceptions are associated with current in a circuit like that in Figure 27.11. One is that current comes out of one terminal of the battery and is then “used up” as it passes through the resistor, leaving current in only one part of the circuit. The current is actually the same *everywhere* in the circuit. A related misconception has the current coming out of the resistor being smaller than that going in because some of the current is “used up.” Yet another misconception has current coming out of both terminals of the battery, in opposite directions, and then “clashing” in the resistor, delivering the energy in this manner. That is not the case; charges flow in the same rotational sense at *all* points in the circuit.

Pitfall Prevention 27.7

Energy Is Not “Dissipated” In some books, you may see Equation 27.22 described as the power “dissipated in” a resistor, suggesting that energy disappears. Instead, we say energy is “delivered to” a resistor.

⁴This usage is another misuse of the word *heat* that is ingrained in our common language.

⁵It is commonly called *joule heating* even though the process of heat does not occur when energy delivered to a resistor appears as internal energy. It is another example of incorrect usage of the word *heat* that has become entrenched in our language.

Figure 27.12 These power lines transfer energy from the electric company to homes and businesses. The energy is transferred at a very high voltage, possibly hundreds of thousands of volts in some cases. Even though it makes power lines very dangerous, the high voltage results in less loss of energy due to resistance in the wires.



Lester Lefkowitz/Taxi/Getty Images

When transporting energy by electricity through power lines (Fig. 27.12), you should not assume the lines have zero resistance. Real power lines do indeed have resistance, and power is delivered to the resistance of these wires. Utility companies seek to minimize the energy transformed to internal energy in the lines and maximize the energy delivered to the consumer. Because $P = I\Delta V$, the same amount of energy can be transported either at high currents and low potential differences or at low currents and high potential differences. Utility companies choose to transport energy at low currents and high potential differences primarily for economic reasons. Copper wire is very expensive, so it is cheaper to use high-resistance wire (that is, wire having a small cross-sectional area; see Eq. 27.10). Therefore, in the expression for the power delivered to a resistor, $P = I^2R$, the resistance of the wire is fixed at a relatively high value for economic considerations. The I^2R loss can be reduced by keeping the current I as low as possible, which means transferring the energy at a high voltage. In some instances, power is transported at potential differences as great as 765 kV. At the destination of the energy, the potential difference is usually reduced to 4 kV by a device called a *transformer*. Another transformer drops the potential difference to 240 V for use in your home. Of course, each time the potential difference decreases, the current increases by the same factor and the power remains the same. We shall discuss transformers in greater detail in Chapter 33.

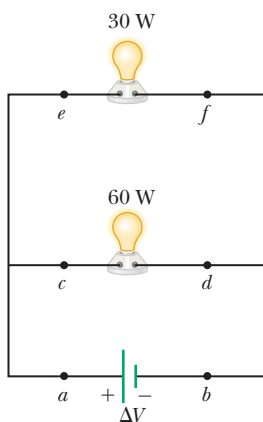

Figure 27.13 (Quick Quiz 27.5) Two lightbulbs connected across the same potential difference.

Quick Quiz 27.5 For the two lightbulbs shown in Figure 27.13, rank the current values at points a through f from greatest to least.

Example 27.4 Power in an Electric Heater

An electric heater is constructed by applying a potential difference of 120 V across a Nichrome wire that has a total resistance of $8.00\ \Omega$. Find the current carried by the wire and the power rating of the heater.

SOLUTION

Conceptualize As discussed in Example 27.2, Nichrome wire has high resistivity and is often used for heating elements in toasters, irons, and electric heaters. Therefore, we expect the power delivered to the wire to be relatively high.

Categorize We evaluate the power from Equation 27.22, so we categorize this example as a substitution problem.

Use Equation 27.7 to find the current in the wire:
$$I = \frac{\Delta V}{R} = \frac{120\ \text{V}}{8.00\ \Omega} = 15.0\ \text{A}$$

Find the power rating using the expression $P = I^2R$ from Equation 27.22:
$$P = I^2R = (15.0\ \text{A})^2(8.00\ \Omega) = 1.80 \times 10^3\ \text{W} = 1.80\ \text{kW}$$

WHAT IF? What if the heater were accidentally connected to a 240-V supply? (That is difficult to do because the shape and orientation of the metal contacts in 240-V plugs are different from those in 120-V plugs.) How would that affect the current carried by the heater and the power rating of the heater, assuming the resistance remains constant?

Answer If the applied potential difference were doubled, Equation 27.7 shows that the current would double. According to Equation 27.22, $P = (\Delta V)^2/R$, the power would be four times larger.

Example 27.5 Linking Electricity and Thermodynamics AM

An immersion heater must increase the temperature of 1.50 kg of water from 10.0°C to 50.0°C in 10.0 min while operating at 110 V.

(A) What is the required resistance of the heater?

SOLUTION

Conceptualize An immersion heater is a resistor that is inserted into a container of water. As energy is delivered to the immersion heater, raising its temperature, energy leaves the surface of the resistor by heat, going into the water. When the immersion heater reaches a constant temperature, the rate of energy delivered to the resistance by electrical transmission (T_{ET}) is equal to the rate of energy delivered by heat (Q) to the water.

Categorize This example allows us to link our new understanding of power in electricity with our experience with specific heat in thermodynamics (Chapter 20). The water is a *nonisolated system*. Its internal energy is rising because of energy transferred into the water by heat from the resistor, so Equation 8.2 reduces to $\Delta E_{\text{int}} = Q$. In our model, we assume the energy that enters the water from the heater remains in the water.

Analyze To simplify the analysis, let's ignore the initial period during which the temperature of the resistor increases and also ignore any variation of resistance with temperature. Therefore, we imagine a constant rate of energy transfer for the entire 10.0 min.

Set the rate of energy delivered to the resistor equal to the rate of energy Q entering the water by heat:

$$P = \frac{(\Delta V)^2}{R} = \frac{Q}{\Delta t}$$

Use Equation 20.4, $Q = mc \Delta T$, to relate the energy input by heat to the resulting temperature change of the water and solve for the resistance:

$$\frac{(\Delta V)^2}{R} = \frac{mc \Delta T}{\Delta t} \rightarrow R = \frac{(\Delta V)^2 \Delta t}{mc \Delta T}$$

Substitute the values given in the statement of the problem:

$$R = \frac{(110 \text{ V})^2(600 \text{ s})}{(1.50 \text{ kg})(4186 \text{ J/kg} \cdot ^\circ\text{C})(50.0^\circ\text{C} - 10.0^\circ\text{C})} = 28.9 \Omega$$

(B) Estimate the cost of heating the water.

SOLUTION

Multiply the power by the time interval to find the amount of energy transferred to the resistor:

$$T_{\text{ET}} = P \Delta t = \frac{(\Delta V)^2}{R} \Delta t = \frac{(110 \text{ V})^2}{28.9 \Omega} (10.0 \text{ min}) \left(\frac{1 \text{ h}}{60.0 \text{ min}} \right) \\ = 69.8 \text{ Wh} = 0.0698 \text{ kWh}$$

Find the cost knowing that energy is purchased at an estimated price of 11¢ per kilowatt-hour:

$$\text{Cost} = (0.0698 \text{ kWh})(\$0.11/\text{kWh}) = \$0.008 = 0.8\text{¢}$$

Finalize The cost to heat the water is very low, less than one cent. In reality, the cost is higher because some energy is transferred from the water into the surroundings by heat and electromagnetic radiation while its temperature is increasing. If you have electrical devices in your home with power ratings on them, use this power rating and an approximate time interval of use to estimate the cost for one use of the device.

Summary

Definitions

The electric **current** I in a conductor is defined as

$$I \equiv \frac{dQ}{dt} \quad (27.2)$$

where dQ is the charge that passes through a cross section of the conductor in a time interval dt . The SI unit of current is the **ampere** (A), where 1 A = 1 C/s.

continued

The **current density** J in a conductor is the current per unit area:

$$J \equiv \frac{I}{A} \quad (27.5)$$

The **resistance** R of a conductor is defined as

$$R \equiv \frac{\Delta V}{I} \quad (27.7)$$

where ΔV is the potential difference across the conductor and I is the current it carries. The SI unit of resistance is volts per ampere, which is defined to be 1 **ohm** (Ω); that is, $1 \Omega = 1 \text{ V/A}$.

Concepts and Principles

The average current in a conductor is related to the motion of the charge carriers through the relationship

$$I_{\text{avg}} = nqv_d A \quad (27.4)$$

where n is the density of charge carriers, q is the charge on each carrier, v_d is the drift speed, and A is the cross-sectional area of the conductor.

The current density in an ohmic conductor is proportional to the electric field according to the expression

$$J = \sigma E \quad (27.6)$$

The proportionality constant σ is called the **conductivity** of the material of which the conductor is made. The inverse of σ is known as **resistivity** ρ (that is, $\rho = 1/\sigma$). Equation 27.6 is known as **Ohm's law**, and a material is said to obey this law if the ratio of its current density to its applied electric field is a constant that is independent of the applied field.

For a uniform block of material of cross-sectional area A and length ℓ , the resistance over the length ℓ is

$$R = \rho \frac{\ell}{A} \quad (27.10)$$

where ρ is the resistivity of the material.

In a classical model of electrical conduction in metals, the electrons are treated as molecules of a gas. In the absence of an electric field, the average velocity of the electrons is zero. When an electric field is applied, the electrons move (on average) with a **drift velocity** \vec{v}_d that is opposite the electric field. The drift velocity is given by

$$\vec{v}_d = \frac{q\vec{E}}{m_e} \tau \quad (27.13)$$

where q is the electron's charge, m_e is the mass of the electron, and τ is the average time interval between electron-atom collisions. According to this model, the resistivity of the metal is

$$\rho = \frac{m_e}{nq^2\tau} \quad (27.16)$$

where n is the number of free electrons per unit volume.

The resistivity of a conductor varies approximately linearly with temperature according to the expression

$$\rho = \rho_0[1 + \alpha(T - T_0)] \quad (27.18)$$

where ρ_0 is the resistivity at some reference temperature T_0 and α is the **temperature coefficient of resistivity**.

If a potential difference ΔV is maintained across a circuit element, the **power**, or rate at which energy is supplied to the element, is

$$P = I\Delta V \quad (27.21)$$

Because the potential difference across a resistor is given by $\Delta V = IR$, we can express the power delivered to a resistor as

$$P = I^2 R = \frac{(\Delta V)^2}{R} \quad (27.22)$$

The energy delivered to a resistor by electrical transmission T_{ET} appears in the form of internal energy E_{int} in the resistor.

Objective Questions

1. denotes answer available in *Student Solutions Manual/Study Guide*

- Car batteries are often rated in ampere-hours. Does this information designate the amount of (a) current, (b) power, (c) energy, (d) charge, or (e) potential the battery can supply?
- Two wires A and B with circular cross sections are made of the same metal and have equal lengths, but the resistance of wire A is three times greater than that of wire B. (i) What is the ratio of the cross-sectional

- area of A to that of B? (a) 3 (b) $\sqrt{3}$ (c) 1 (d) $1/\sqrt{3}$ (e) $\frac{1}{3}$ (ii) What is the ratio of the radius of A to that of B? Choose from the same possibilities as in part (i).
- A cylindrical metal wire at room temperature is carrying electric current between its ends. One end is at potential $V_A = 50$ V, and the other end is at potential $V_B = 0$ V. Rank the following actions in terms of the change that each one separately would produce in the current from the greatest increase to the greatest decrease. In your ranking, note any cases of equality. (a) Make $V_A = 150$ V with $V_B = 0$ V. (b) Adjust V_A to triple the power with which the wire converts electrically transmitted energy into internal energy. (c) Double the radius of the wire. (d) Double the length of the wire. (e) Double the Celsius temperature of the wire.
 - A current-carrying ohmic metal wire has a cross-sectional area that gradually becomes smaller from one end of the wire to the other. The current has the same value for each section of the wire, so charge does not accumulate at any one point. (i) How does the drift speed vary along the wire as the area becomes smaller? (a) It increases. (b) It decreases. (c) It remains constant. (ii) How does the resistance per unit length vary along the wire as the area becomes smaller? Choose from the same possibilities as in part (i).
 - A potential difference of 1.00 V is maintained across a 10.0- Ω resistor for a period of 20.0 s. What total charge passes by a point in one of the wires connected to the resistor in this time interval? (a) 200 C (b) 20.0 C (c) 2.00 C (d) 0.005 00 C (e) 0.050 0 C
 - Three wires are made of copper having circular cross sections. Wire 1 has a length L and radius r . Wire 2 has a length L and radius $2r$. Wire 3 has a length $2L$ and radius $3r$. Which wire has the smallest resistance? (a) wire 1 (b) wire 2 (c) wire 3 (d) All have the same resistance. (e) Not enough information is given to answer the question.
 - A metal wire of resistance R is cut into three equal pieces that are then placed together side by side to form a new cable with a length equal to one-third the original length. What is the resistance of this new cable? (a) $\frac{1}{9}R$ (b) $\frac{1}{3}R$ (c) R (d) $3R$ (e) $9R$
 - A metal wire has a resistance of 10.0 Ω at a temperature of 20.0°C. If the same wire has a resistance of 10.6 Ω at 90.0°C, what is the resistance of this wire when its temperature is -20.0°C? (a) 0.700 Ω (b) 9.66 Ω (c) 10.3 Ω (d) 13.8 Ω (e) 6.59 Ω
 - The current-versus-voltage behavior of a certain electrical device is shown in Figure OQ27.9. When the potential difference across the device is 2 V, what is its resistance? (a) 1 Ω (b) $\frac{3}{4}$ Ω (c) $\frac{4}{3}$ Ω (d) undefined (e) none of those answers
 - Two conductors made of the same material are connected across the same potential difference. Conductor A has twice the diameter and twice the length of conductor B. What is the ratio of the power delivered to A to the power delivered to B? (a) 8 (b) 4 (c) 2 (d) 1 (e) $\frac{1}{2}$
 - Two conducting wires A and B of the same length and radius are connected across the same potential difference. Conductor A has twice the resistivity of conductor B. What is the ratio of the power delivered to A to the power delivered to B? (a) 2 (b) $\sqrt{2}$ (c) 1 (d) $1/\sqrt{2}$ (e) $\frac{1}{2}$
 - Two lightbulbs both operate on 120 V. One has a power of 25 W and the other 100 W. (i) Which lightbulb has higher resistance? (a) The dim 25-W lightbulb does. (b) The bright 100-W lightbulb does. (c) Both are the same. (ii) Which lightbulb carries more current? Choose from the same possibilities as in part (i).
 - Wire B has twice the length and twice the radius of wire A. Both wires are made from the same material. If wire A has a resistance R , what is the resistance of wire B? (a) $4R$ (b) $2R$ (c) R (d) $\frac{1}{2}R$ (e) $\frac{1}{4}R$

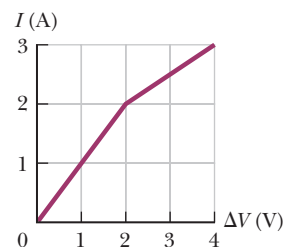

Figure OQ27.9

Conceptual Questions

1. denotes answer available in *Student Solutions Manual/Study Guide*

- If you were to design an electric heater using Nichrome wire as the heating element, what parameters of the wire could you vary to meet a specific power output such as 1 000 W?
- What factors affect the resistance of a conductor?
- When the potential difference across a certain conductor is doubled, the current is observed to increase by a factor of 3. What can you conclude about the conductor?
- Over the time interval after a difference in potential is applied between the ends of a wire, what would happen to the drift velocity of the electrons in a wire and to the current in the wire if the electrons could move freely without resistance through the wire?
- How does the resistance for copper and for silicon change with temperature? Why are the behaviors of these two materials different?
- Use the atomic theory of matter to explain why the resistance of a material should increase as its temperature increases.
- If charges flow very slowly through a metal, why does it not require several hours for a light to come on when you throw a switch?
- Newspaper articles often contain statements such as "10 000 volts of electricity surged through the victim's body." What is wrong with this statement?

Problems

WebAssign The problems found in this chapter may be assigned online in Enhanced WebAssign

1. straightforward; 2. intermediate; 3. challenging

1. full solution available in the *Student Solutions Manual/Study Guide*

AMT Analysis Model tutorial available in Enhanced WebAssign

GP Guided Problem

M Master It tutorial available in Enhanced WebAssign

W Watch It video solution available in Enhanced WebAssign

Section 27.1 Electric Current

AMT 1. A 200-km-long high-voltage transmission line 2.00 cm in diameter carries a steady current of 1 000 A. If the conductor is copper with a free charge density of 8.50×10^{28} electrons per cubic meter, how many years does it take one electron to travel the full length of the cable?

M 2. A small sphere that carries a charge q is whirled in a circle at the end of an insulating string. The angular frequency of revolution is ω . What average current does this revolving charge represent?

W 3. An aluminum wire having a cross-sectional area equal to $4.00 \times 10^{-6} \text{ m}^2$ carries a current of 5.00 A. The density of aluminum is 2.70 g/cm^3 . Assume each aluminum atom supplies one conduction electron per atom. Find the drift speed of the electrons in the wire.

AMT 4. In the Bohr model of the hydrogen atom (which will be covered in detail in Chapter 42), an electron in the lowest energy state moves at a speed of $2.19 \times 10^6 \text{ m/s}$ in a circular path of radius $5.29 \times 10^{-11} \text{ m}$. What is the effective current associated with this orbiting electron?

5. A proton beam in an accelerator carries a current of $125 \mu\text{A}$. If the beam is incident on a target, how many protons strike the target in a period of 23.0 s?

6. A copper wire has a circular cross section with a radius of 1.25 mm. (a) If the wire carries a current of 3.70 A, find the drift speed of the electrons in this wire. (b) All other things being equal, what happens to the drift speed in wires made of metal having a larger number of conduction electrons per atom than copper? Explain.

7. Suppose the current in a conductor decreases exponentially with time according to the equation $I(t) = I_0 e^{-t/\tau}$, where I_0 is the initial current (at $t = 0$) and τ is a constant having dimensions of time. Consider a fixed observation point within the conductor. (a) How much charge passes this point between $t = 0$ and $t = \tau$? (b) How much charge passes this point between $t = 0$ and $t = 10\tau$? (c) **What If?** How much charge passes this point between $t = 0$ and $t = \infty$?

W 8. Figure P27.8 represents a section of a conductor of nonuniform diameter carrying a current of $I = 5.00 \text{ A}$. The radius of cross-section A_1 is $r_1 = 0.400 \text{ cm}$. (a) What is the magnitude of the current density across A_1 ? The radius r_2 at A_2 is larger than the radius r_1 at A_1 .

(b) Is the current at A_2 larger, smaller, or the same? (c) Is the current density at A_2 larger, smaller, or the same? Assume $A_2 = 4A_1$. Specify the (d) radius, (e) current, and (f) current density at A_2 .

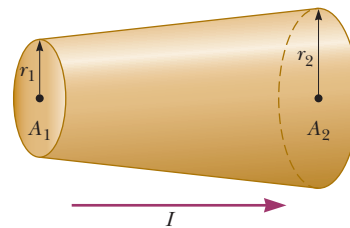

Figure P27.8

W 9. The quantity of charge q (in coulombs) that has passed through a surface of area 2.00 cm^2 varies with time according to the equation $q = 4t^3 + 5t + 6$, where t is in seconds. (a) What is the instantaneous current through the surface at $t = 1.00 \text{ s}$? (b) What is the value of the current density?

10. A Van de Graaff generator produces a beam of 2.00-MeV deuterons, which are heavy hydrogen nuclei containing a proton and a neutron. (a) If the beam current is $10.0 \mu\text{A}$, what is the average separation of the deuterons? (b) Is the electrical force of repulsion among them a significant factor in beam stability? Explain.

M 11. The electron beam emerging from a certain high-energy electron accelerator has a circular cross section of radius 1.00 mm. (a) The beam current is $8.00 \mu\text{A}$. Find the current density in the beam assuming it is uniform throughout. (b) The speed of the electrons is so close to the speed of light that their speed can be taken as 300 Mm/s with negligible error. Find the electron density in the beam. (c) Over what time interval does Avogadro's number of electrons emerge from the accelerator?

W 12. An electric current in a conductor varies with time according to the expression $I(t) = 100 \sin(120\pi t)$, where I is in amperes and t is in seconds. What is the total charge passing a given point in the conductor from $t = 0$ to $t = \frac{1}{240} \text{ s}$?

W 13. A teapot with a surface area of 700 cm^2 is to be plated with silver. It is attached to the negative electrode of an electrolytic cell containing silver nitrate (Ag^+NO_3^-). The cell is powered by a 12.0-V battery and has a

resistance of $1.80\ \Omega$. If the density of silver is $10.5 \times 10^3\ \text{kg/m}^3$, over what time interval does a 0.133-mm layer of silver build up on the teapot?

Section 27.2 Resistance

14. A lightbulb has a resistance of $240\ \Omega$ when operating with a potential difference of $120\ \text{V}$ across it. What is the current in the lightbulb?
15. A wire $50.0\ \text{m}$ long and $2.00\ \text{mm}$ in diameter is connected to a source with a potential difference of $9.11\ \text{V}$, and the current is found to be $36.0\ \text{A}$. Assume a temperature of 20.0°C and, using Table 27.2, identify the metal out of which the wire is made.
16. A 0.900-V potential difference is maintained across a 1.50-m length of tungsten wire that has a cross-sectional area of $0.600\ \text{mm}^2$. What is the current in the wire?
17. An electric heater carries a current of $13.5\ \text{A}$ when operating at a voltage of $120\ \text{V}$. What is the resistance of the heater?
18. Aluminum and copper wires of equal length are found to have the same resistance. What is the ratio of their radii?
19. Suppose you wish to fabricate a uniform wire from $1.00\ \text{g}$ of copper. If the wire is to have a resistance of $R = 0.500\ \Omega$ and all the copper is to be used, what must be (a) the length and (b) the diameter of this wire?
20. Suppose you wish to fabricate a uniform wire from a mass m of a metal with density ρ_m and resistivity ρ . If the wire is to have a resistance of R and all the metal is to be used, what must be (a) the length and (b) the diameter of this wire?
21. A portion of Nichrome wire of radius $2.50\ \text{mm}$ is to be used in winding a heating coil. If the coil must draw a current of $9.25\ \text{A}$ when a voltage of $120\ \text{V}$ is applied across its ends, find (a) the required resistance of the coil and (b) the length of wire you must use to wind the coil.

Section 27.3 A Model for Electrical Conduction

22. If the current carried by a conductor is doubled, what happens to (a) the charge carrier density, (b) the current density, (c) the electron drift velocity, and (d) the average time interval between collisions?
23. A current density of $6.00 \times 10^{-13}\ \text{A/m}^2$ exists in the atmosphere at a location where the electric field is $100\ \text{V/m}$. Calculate the electrical conductivity of the Earth's atmosphere in this region.
24. An iron wire has a cross-sectional area equal to $5.00 \times 10^{-6}\ \text{m}^2$. Carry out the following steps to determine the drift speed of the conduction electrons in the wire if it carries a current of $30.0\ \text{A}$. (a) How many kilograms are there in 1.00 mole of iron? (b) Starting with the density of iron and the result of part (a), compute the molar density of iron (the number of moles of iron per cubic meter). (c) Calculate the number density of

iron atoms using Avogadro's number. (d) Obtain the number density of conduction electrons given that there are two conduction electrons per iron atom. (e) Calculate the drift speed of conduction electrons in this wire.

25. If the magnitude of the drift velocity of free electrons in a copper wire is $7.84 \times 10^{-4}\ \text{m/s}$, what is the electric field in the conductor?

Section 27.4 Resistance and Temperature

26. A certain lightbulb has a tungsten filament with a resistance of $19.0\ \Omega$ when at 20.0°C and $140\ \Omega$ when hot. Assume the resistivity of tungsten varies linearly with temperature even over the large temperature range involved here. Find the temperature of the hot filament.
27. What is the fractional change in the resistance of an iron filament when its temperature changes from 25.0°C to 50.0°C ?
28. While taking photographs in Death Valley on a day when the temperature is 58.0°C , Bill Hiker finds that a certain voltage applied to a copper wire produces a current of $1.00\ \text{A}$. Bill then travels to Antarctica and applies the same voltage to the same wire. What current does he register there if the temperature is -88.0°C ? Assume that no change occurs in the wire's shape and size.
29. If a certain silver wire has a resistance of $6.00\ \Omega$ at 20.0°C , what resistance will it have at 34.0°C ?
30. Plethysmographs are devices used for measuring changes in the volume of internal organs or limbs. In one form of this device, a rubber capillary tube with an inside diameter of $1.00\ \text{mm}$ is filled with mercury at 20.0°C . The resistance of the mercury is measured with the aid of electrodes sealed into the ends of the tube. If $100\ \text{cm}$ of the tube is wound in a helix around a patient's upper arm, the blood flow during a heart-beat causes the arm to expand, stretching the length of the tube by $0.0400\ \text{cm}$. From this observation and assuming cylindrical symmetry, you can find the change in volume of the arm, which gives an indication of blood flow. Taking the resistivity of mercury to be $9.58 \times 10^{-7}\ \Omega \cdot \text{m}$, calculate (a) the resistance of the mercury and (b) the fractional change in resistance during the heartbeat. *Hint:* The fraction by which the cross-sectional area of the mercury column decreases is the fraction by which the length increases because the volume of mercury is constant.
31. (a) A 34.5-m length of copper wire at 20.0°C has a radius of $0.25\ \text{mm}$. If a potential difference of $9.00\ \text{V}$ is applied across the length of the wire, determine the current in the wire. (b) If the wire is heated to 30.0°C while the 9.00-V potential difference is maintained, what is the resulting current in the wire?
32. An engineer needs a resistor with a zero overall temperature coefficient of resistance at 20.0°C . She designs a pair of circular cylinders, one of carbon and one of Nichrome as shown in Figure P27.32 (page 828). The

device must have an overall resistance of $R_1 + R_2 = 10.0\ \Omega$ independent of temperature and a uniform radius of $r = 1.50\ \text{mm}$. Ignore thermal expansion of the cylinders and assume both are always at the same temperature.

(a) Can she meet the design goal with this method?
 (b) If so, state what you can determine about the lengths ℓ_1 and ℓ_2 of each segment. If not, explain.



Figure P27.32

- 33.** An aluminum wire with a diameter of $0.100\ \text{mm}$ has a uniform electric field of $0.200\ \text{V/m}$ imposed along its entire length. The temperature of the wire is 50.0°C . Assume one free electron per atom. (a) Use the information in Table 27.2 to determine the resistivity of aluminum at this temperature. (b) What is the current density in the wire? (c) What is the total current in the wire? (d) What is the drift speed of the conduction electrons? (e) What potential difference must exist between the ends of a 2.00-m length of the wire to produce the stated electric field?
- 34. Review.** An aluminum rod has a resistance of $1.23\ \Omega$ at 20.0°C . Calculate the resistance of the rod at 120°C by accounting for the changes in both the resistivity and the dimensions of the rod. The coefficient of linear expansion for aluminum is $2.40 \times 10^{-6}\ (\text{C}^\circ)^{-1}$.
- 35.** At what temperature will aluminum have a resistivity that is three times the resistivity copper has at room temperature?

Section 27.6 Electrical Power

- 36.** Assume that global lightning on the Earth constitutes a constant current of $1.00\ \text{kA}$ between the ground and an atmospheric layer at potential $300\ \text{kV}$. (a) Find the power of terrestrial lightning. (b) For comparison, find the power of sunlight falling on the Earth. Sunlight has an intensity of $1\ 370\ \text{W/m}^2$ above the atmosphere. Sunlight falls perpendicularly on the circular projected area that the Earth presents to the Sun.
- 37.** In a hydroelectric installation, a turbine delivers $1\ 500\ \text{hp}$ to a generator, which in turn transfers 80.0% of the mechanical energy out by electrical transmission. Under these conditions, what current does the generator deliver at a terminal potential difference of $2\ 000\ \text{V}$?
- 38.** A Van de Graaff generator (see Fig. 25.23) is operating so that the potential difference between the high-potential electrode \textcircled{B} and the charging needles at \textcircled{A} is $15.0\ \text{kV}$. Calculate the power required to drive the belt against electrical forces at an instant when the effective current delivered to the high-potential electrode is $500\ \mu\text{A}$.
- 39.** A certain waffle iron is rated at $1.00\ \text{kW}$ when connected to a 120-V source. (a) What current does the waffle iron carry? (b) What is its resistance?
- 40.** The potential difference across a resting neuron in the human body is about $75.0\ \text{mV}$ and carries a current of about $0.200\ \text{mA}$. How much power does the neuron release?
- 41.** Suppose your portable DVD player draws a current of $350\ \text{mA}$ at $6.00\ \text{V}$. How much power does the player require?
- 42. Review.** A well-insulated electric water heater warms **AMT** $109\ \text{kg}$ of water from 20.0°C to 49.0°C in $25.0\ \text{min}$. **M** Find the resistance of its heating element, which is connected across a 240-V potential difference.
- 43.** A 100-W lightbulb connected to a 120-V source experiences a voltage surge that produces $140\ \text{V}$ for a moment. By what percentage does its power output increase? Assume its resistance does not change.
- 44.** The cost of energy delivered to residences by electrical transmission varies from $\$0.070/\text{kWh}$ to $\$0.258/\text{kWh}$ throughout the United States; $\$0.110/\text{kWh}$ is the average value. At this average price, calculate the cost of (a) leaving a 40.0-W porch light on for two weeks while you are on vacation, (b) making a piece of dark toast in $3.00\ \text{min}$ with a 970-W toaster, and (c) drying a load of clothes in $40.0\ \text{min}$ in a $5.20 \times 10^3\text{-W}$ dryer.
- 45.** Batteries are rated in terms of ampere-hours ($\text{A} \cdot \text{h}$). **W** For example, a battery that can produce a current of $2.00\ \text{A}$ for $3.00\ \text{h}$ is rated at $6.00\ \text{A} \cdot \text{h}$. (a) What is the total energy, in kilowatt-hours, stored in a 12.0-V battery rated at $55.0\ \text{A} \cdot \text{h}$? (b) At $\$0.110$ per kilowatt-hour, what is the value of the electricity produced by this battery?
- 46.** Residential building codes typically require the use **W** of 12-gauge copper wire (diameter $0.205\ \text{cm}$) for wiring receptacles. Such circuits carry currents as large as $20.0\ \text{A}$. If a wire of smaller diameter (with a higher gauge number) carried that much current, the wire could rise to a high temperature and cause a fire. (a) Calculate the rate at which internal energy is produced in $1.00\ \text{m}$ of 12-gauge copper wire carrying $20.0\ \text{A}$. (b) **What If?** Repeat the calculation for a 12-gauge aluminum wire. (c) Explain whether a 12-gauge aluminum wire would be as safe as a copper wire.
- 47.** Assuming the cost of energy from the electric company **M** is $\$0.110/\text{kWh}$, compute the cost per day of operating a lamp that draws a current of $1.70\ \text{A}$ from a 110-V line.
- 48.** An 11.0-W energy-efficient fluorescent lightbulb is designed to produce the same illumination as a conventional 40.0-W incandescent lightbulb. Assuming a cost of $\$0.110/\text{kWh}$ for energy from the electric company, how much money does the user of the energy-efficient bulb save during $100\ \text{h}$ of use?
- 49.** A coil of Nichrome wire is $25.0\ \text{m}$ long. The wire has a diameter of $0.400\ \text{mm}$ and is at 20.0°C . If it carries a current of $0.500\ \text{A}$, what are (a) the magnitude of the electric field in the wire and (b) the power delivered to it? (c) **What If?** If the temperature is increased to 340°C and the potential difference across the wire remains constant, what is the power delivered?
- 50. Review.** A rechargeable battery of mass $15.0\ \text{g}$ delivers an average current of $18.0\ \text{mA}$ to a portable DVD player at $1.60\ \text{V}$ for $2.40\ \text{h}$ before the battery must be

- recharged. The recharger maintains a potential difference of 2.30 V across the battery and delivers a charging current of 13.5 mA for 4.20 h. (a) What is the efficiency of the battery as an energy storage device? (b) How much internal energy is produced in the battery during one charge–discharge cycle? (c) If the battery is surrounded by ideal thermal insulation and has an effective specific heat of $975 \text{ J/kg} \cdot ^\circ\text{C}$, by how much will its temperature increase during the cycle?
51. A 500-W heating coil designed to operate from 110 V is made of Nichrome wire 0.500 mm in diameter. (a) Assuming the resistivity of the Nichrome remains constant at its 20.0°C value, find the length of wire used. (b) **What If?** Now consider the variation of resistivity with temperature. What power is delivered to the coil of part (a) when it is warmed to 1200°C ?
52. *Why is the following situation impossible?* A politician is decrying wasteful uses of energy and decides to focus on energy used to operate plug-in electric clocks in the United States. He estimates there are 270 million of these clocks, approximately one clock for each person in the population. The clocks transform energy taken in by electrical transmission at the average rate 2.50 W. The politician gives a speech in which he complains that, at today's electrical rates, the nation is losing \$100 million every year to operate these clocks.
53. **M** A certain toaster has a heating element made of Nichrome wire. When the toaster is first connected to a 120-V source (and the wire is at a temperature of 20.0°C), the initial current is 1.80 A. The current decreases as the heating element warms up. When the toaster reaches its final operating temperature, the current is 1.53 A. (a) Find the power delivered to the toaster when it is at its operating temperature. (b) What is the final temperature of the heating element?
54. Make an order-of-magnitude estimate of the cost of one person's routine use of a handheld hair dryer for 1 year. If you do not use a hair dryer yourself, observe or interview someone who does. State the quantities you estimate and their values.
55. **Review.** The heating element of an electric coffee maker operates at 120 V and carries a current of 2.00 A. Assuming the water absorbs all the energy delivered to the resistor, calculate the time interval during which the temperature of 0.500 kg of water rises from room temperature (23.0°C) to the boiling point.
56. A 120-V motor has mechanical power output of 2.50 hp. It is 90.0% efficient in converting power that it takes in by electrical transmission into mechanical power. (a) Find the current in the motor. (b) Find the energy delivered to the motor by electrical transmission in 3.00 h of operation. (c) If the electric company charges $\$0.110/\text{kWh}$, what does it cost to run the motor for 3.00 h?
- 48 W of power when connected across a 20-V battery. What length of wire is required?
58. Determine the temperature at which the resistance of an aluminum wire will be twice its value at 20.0°C . Assume its coefficient of resistivity remains constant.
59. A car owner forgets to turn off the headlights of his car while it is parked in his garage. If the 12.0-V battery in his car is rated at $90.0 \text{ A} \cdot \text{h}$ and each headlight requires 36.0 W of power, how long will it take the battery to completely discharge?
60. Lightbulb A is marked “25 W 120 V,” and lightbulb B is marked “100 W 120 V.” These labels mean that each lightbulb has its respective power delivered to it when it is connected to a constant 120-V source. (a) Find the resistance of each lightbulb. (b) During what time interval does 1.00 C pass into lightbulb A? (c) Is this charge different upon its exit versus its entry into the lightbulb? Explain. (d) In what time interval does 1.00 J pass into lightbulb A? (e) By what mechanisms does this energy enter and exit the lightbulb? Explain. (f) Find the cost of running lightbulb A continuously for 30.0 days, assuming the electric company sells its product at $\$0.110$ per kWh.
61. One wire in a high-voltage transmission line carries **W** 1 000 A starting at 700 kV for a distance of 100 mi. If the resistance in the wire is $0.500 \Omega/\text{mi}$, what is the power loss due to the resistance of the wire?
62. An experiment is conducted to measure the electrical resistivity of Nichrome in the form of wires with different lengths and cross-sectional areas. For one set of measurements, a student uses 30-gauge wire, which has a cross-sectional area of $7.30 \times 10^{-8} \text{ m}^2$. The student measures the potential difference across the wire and the current in the wire with a voltmeter and an ammeter, respectively. (a) For each set of measurements given in the table taken on wires of three different lengths, calculate the resistance of the wires and the corresponding values of the resistivity. (b) What is the average value of the resistivity? (c) Explain how this value compares with the value given in Table 27.2.

L (m)	ΔV (V)	I (A)	R (Ω)	ρ ($\Omega \cdot \text{m}$)
0.540	5.22	0.72		
1.028	5.82	0.414		
1.543	5.94	0.281		

63. A charge Q is placed on a capacitor of capacitance C . The capacitor is connected into the circuit shown in Figure P27.63, with an open switch, a resistor, and an initially uncharged capacitor of capacitance $3C$. The

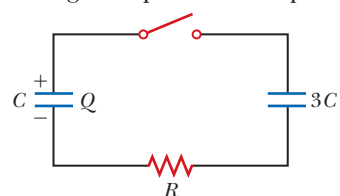

Figure P27.63

Additional Problems

57. A particular wire has a resistivity of $3.0 \times 10^{-8} \Omega \cdot \text{m}$ and a cross-sectional area of $4.0 \times 10^{-6} \text{ m}^2$. A length of this wire is to be used as a resistor that will receive

- switch is then closed, and the circuit comes to equilibrium. In terms of Q and C , find (a) the final potential difference between the plates of each capacitor, (b) the charge on each capacitor, and (c) the final energy stored in each capacitor. (d) Find the internal energy appearing in the resistor.
- 64. Review.** An office worker uses an immersion heater to warm 250 g of water in a light, covered, insulated cup from 20.0°C to 100°C in 4.00 min. The heater is a Nichrome resistance wire connected to a 120-V power supply. Assume the wire is at 100°C throughout the 4.00-min time interval. (a) Specify a relationship between a diameter and a length that the wire can have. (b) Can it be made from less than 0.500 cm³ of Nichrome?
- 65.** An x-ray tube used for cancer therapy operates at 4.00 MV with electrons constituting a beam current of 25.0 mA striking a metal target. Nearly all the power in the beam is transferred to a stream of water flowing through holes drilled in the target. What rate of flow, in kilograms per second, is needed if the rise in temperature of the water is not to exceed 50.0°C?
- 66.** **AMT** **M** An all-electric car (not a hybrid) is designed to run from a bank of 12.0-V batteries with total energy storage of 2.00×10^7 J. If the electric motor draws 8.00 kW as the car moves at a steady speed of 20.0 m/s, (a) what is the current delivered to the motor? (b) How far can the car travel before it is “out of juice”?
- 67.** A straight, cylindrical wire lying along the x axis has a length of 0.500 m and a diameter of 0.200 mm. It is made of a material described by Ohm’s law with a resistivity of $\rho = 4.00 \times 10^{-8} \Omega \cdot \text{m}$. Assume a potential of 4.00 V is maintained at the left end of the wire at $x = 0$. Also assume $V = 0$ at $x = 0.500$ m. Find (a) the magnitude and direction of the electric field in the wire, (b) the resistance of the wire, (c) the magnitude and direction of the electric current in the wire, and (d) the current density in the wire. (e) Show that $E = \rho j$.
- 68.** A straight, cylindrical wire lying along the x axis has a length L and a diameter d . It is made of a material described by Ohm’s law with a resistivity ρ . Assume potential V is maintained at the left end of the wire at $x = 0$. Also assume the potential is zero at $x = L$. In terms of L , d , V , ρ , and physical constants, derive expressions for (a) the magnitude and direction of the electric field in the wire, (b) the resistance of the wire, (c) the magnitude and direction of the electric current in the wire, and (d) the current density in the wire. (e) Show that $E = \rho j$.
- 69.** **W** An electric utility company supplies a customer’s house from the main power lines (120 V) with two copper wires, each of which is 50.0 m long and has a resistance of 0.108 Ω per 300 m. (a) Find the potential difference at the customer’s house for a load current of 110 A. For this load current, find (b) the power delivered to the customer and (c) the rate at which internal energy is produced in the copper wires.
- 70.** The strain in a wire can be monitored and computed by measuring the resistance of the wire. Let L_i represent the original length of the wire, A_i its original cross-sectional area, $R_i = \rho L_i/A_i$ the original resistance between its ends, and $\delta = \Delta L/L_i = (L - L_i)/L_i$ the strain resulting from the application of tension. Assume the resistivity and the volume of the wire do not change as the wire stretches. (a) Show that the resistance between the ends of the wire under strain is given by $R = R_i(1 + 2\delta + \delta^2)$. (b) If the assumptions are precisely true, is this result exact or approximate? Explain your answer.
- 71.** An oceanographer is studying how the ion concentration in seawater depends on depth. She makes a measurement by lowering into the water a pair of concentric metallic cylinders (Fig. P27.71) at the end of a cable and taking data to determine the resistance between these electrodes as a function of depth. The water between the two cylinders forms a cylindrical shell of inner radius r_a , outer radius r_b , and length L much larger than r_b . The scientist applies a potential difference ΔV between the inner and outer surfaces, producing an outward radial current I . Let ρ represent the resistivity of the water. (a) Find the resistance of the water between the cylinders in terms of L , ρ , r_a , and r_b . (b) Express the resistivity of the water in terms of the measured quantities L , r_a , r_b , ΔV , and I .

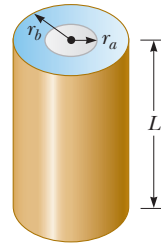

Figure P27.71

- 72.** Why is the following situation impossible? An inquisitive physics student takes a 100-W incandescent lightbulb out of its socket and measures its resistance with an ohmmeter. He measures a value of 10.5 Ω . He is able to connect an ammeter to the lightbulb socket to correctly measure the current drawn by the bulb while operating. Inserting the bulb back into the socket and operating the bulb from a 120-V source, he measures the current to be 11.4 A.
- 73.** The temperature coefficients of resistivity α in Table 27.2 are based on a reference temperature T_0 of 20.0°C. Suppose the coefficients were given the symbol α' and were based on a T_0 of 0°C. What would the coefficient α' for silver be? *Note:* The coefficient α satisfies $\rho = \rho_0[1 + \alpha(T - T_0)]$, where ρ_0 is the resistivity of the material at $T_0 = 20.0^\circ\text{C}$. The coefficient α' must satisfy the expression $\rho = \rho'_0[1 + \alpha'T]$, where ρ'_0 is the resistivity of the material at 0°C.
- 74.** A close analogy exists between the flow of energy by heat because of a temperature difference (see Section 20.7) and the flow of electric charge because of a

potential difference. In a metal, energy dQ and electrical charge dq are both transported by free electrons. Consequently, a good electrical conductor is usually a good thermal conductor as well. Consider a thin conducting slab of thickness dx , area A , and electrical conductivity σ , with a potential difference dV between opposite faces. (a) Show that the current $I = dq/dt$ is given by the equation on the left:

Charge conduction Thermal conduction

$$\frac{dq}{dt} = \sigma A \left| \frac{dV}{dx} \right| \qquad \frac{dQ}{dt} = kA \left| \frac{dT}{dx} \right|$$

In the analogous thermal conduction equation on the right (Eq. 20.15), the rate dQ/dt of energy flow by heat (in SI units of joules per second) is due to a temperature gradient dT/dx in a material of thermal conductivity k . (b) State analogous rules relating the direction of the electric current to the change in potential and relating the direction of energy flow to the change in temperature.

- 75. Review.** When a straight wire is warmed, its resistance is given by $R = R_0[1 + \alpha(T - T_0)]$ according to Equation 27.20, where α is the temperature coefficient of resistivity. This expression needs to be modified if we include the change in dimensions of the wire due to thermal expansion. For a copper wire of radius 0.100 0 mm and length 2.000 m, find its resistance at 100.0°C, including the effects of both thermal expansion and temperature variation of resistivity. Assume the coefficients are known to four significant figures.
- 76. Review.** When a straight wire is warmed, its resistance is given by $R = R_0[1 + \alpha(T - T_0)]$ according to Equation 27.20, where α is the temperature coefficient of resistivity. This expression needs to be modified if we include the change in dimensions of the wire due to thermal expansion. Find a more precise expression for the resistance, one that includes the effects of changes in the dimensions of the wire when it is warmed. Your final expression should be in terms of R_0 , T , T_0 , the temperature coefficient of resistivity α , and the coefficient of linear expansion α' .
- 77. Review.** A parallel-plate capacitor consists of square plates of edge length ℓ that are separated by a distance d , where $d \ll \ell$. A potential difference ΔV is maintained between the plates. A material of dielectric constant κ fills half the space between the plates. The dielectric slab is withdrawn from the capacitor as shown in Figure P27.77. (a) Find the capacitance when

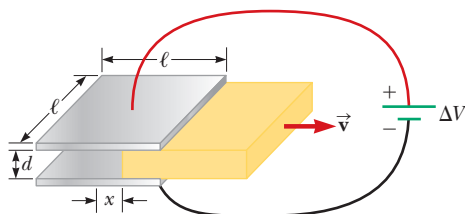

Figure P27.77

the left edge of the dielectric is at a distance x from the center of the capacitor. (b) If the dielectric is removed at a constant speed v , what is the current in the circuit as the dielectric is being withdrawn?

- 78.** The dielectric material between the plates of a parallel-plate capacitor always has some nonzero conductivity σ . Let A represent the area of each plate and d the distance between them. Let κ represent the dielectric constant of the material. (a) Show that the resistance R and the capacitance C of the capacitor are related by

$$RC = \frac{\kappa \epsilon_0}{\sigma}$$

- (b) Find the resistance between the plates of a 14.0-nF capacitor with a fused quartz dielectric.
- 79.** Gold is the most ductile of all metals. For example, one gram of gold can be drawn into a wire 2.40 km long. The density of gold is $19.3 \times 10^3 \text{ kg/m}^3$, and its resistivity is $2.44 \times 10^{-8} \Omega \cdot \text{m}$. What is the resistance of such a wire at 20.0°C?

- 80.** The current–voltage characteristic curve for a semiconductor diode as a function of temperature T is given by

$$I = I_0(e^{e\Delta V/k_B T} - 1)$$

Here the first symbol e represents Euler's number, the base of natural logarithms. The second e is the magnitude of the electron charge, the k_B stands for Boltzmann's constant, and T is the absolute temperature. (a) Set up a spreadsheet to calculate I and $R = \Delta V/I$ for $\Delta V = 0.400 \text{ V}$ to 0.600 V in increments of 0.005 V . Assume $I_0 = 1.00 \text{ nA}$. (b) Plot R versus ΔV for $T = 280 \text{ K}$, 300 K , and 320 K .

- 81.** The potential difference across the filament of a light-bulb is maintained at a constant value while equilibrium temperature is being reached. The steady-state current in the bulb is only one-tenth of the current drawn by the bulb when it is first turned on. If the temperature coefficient of resistivity for the bulb at 20.0°C is $0.00450 (\text{°C})^{-1}$ and the resistance increases linearly with increasing temperature, what is the final operating temperature of the filament?

Challenge Problems

- 82.** A more general definition of the temperature coefficient of resistivity is

$$\alpha = \frac{1}{\rho} \frac{d\rho}{dT}$$

where ρ is the resistivity at temperature T . (a) Assuming α is constant, show that

$$\rho = \rho_0 e^{\alpha(T - T_0)}$$

where ρ_0 is the resistivity at temperature T_0 . (b) Using the series expansion $e^x \approx 1 + x$ for $x \ll 1$, show that the resistivity is given approximately by the expression

$$\rho = \rho_0 [1 + \alpha(T - T_0)] \quad \text{for } \alpha(T - T_0) \ll 1$$

- 83.** A spherical shell with inner radius r_a and outer radius r_b is formed from a material of resistivity ρ . It carries

current radially, with uniform density in all directions. Show that its resistance is

$$R = \frac{\rho}{4\pi} \left(\frac{1}{r_a} - \frac{1}{r_b} \right)$$

- 84.** Material with uniform resistivity ρ is formed into a wedge as shown in Figure P27.84. Show that the resistance between face A and face B of this wedge is

$$R = \rho \frac{L}{w(y_2 - y_1)} \ln \frac{y_2}{y_1}$$

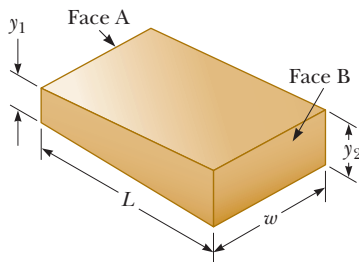

Figure P27.84

- 85.** A material of resistivity ρ is formed into the shape of a truncated cone of height h as shown in Figure P27.85. The bottom end has radius b , and the top end has radius a . Assume the current is distributed uniformly over any circular cross section of the cone so that the current density does not depend on radial position. (The current density does vary with position along the axis of the cone.) Show that the resistance between the two ends is

$$R = \frac{\rho}{\pi} \left(\frac{h}{ab} \right)$$

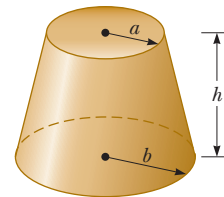
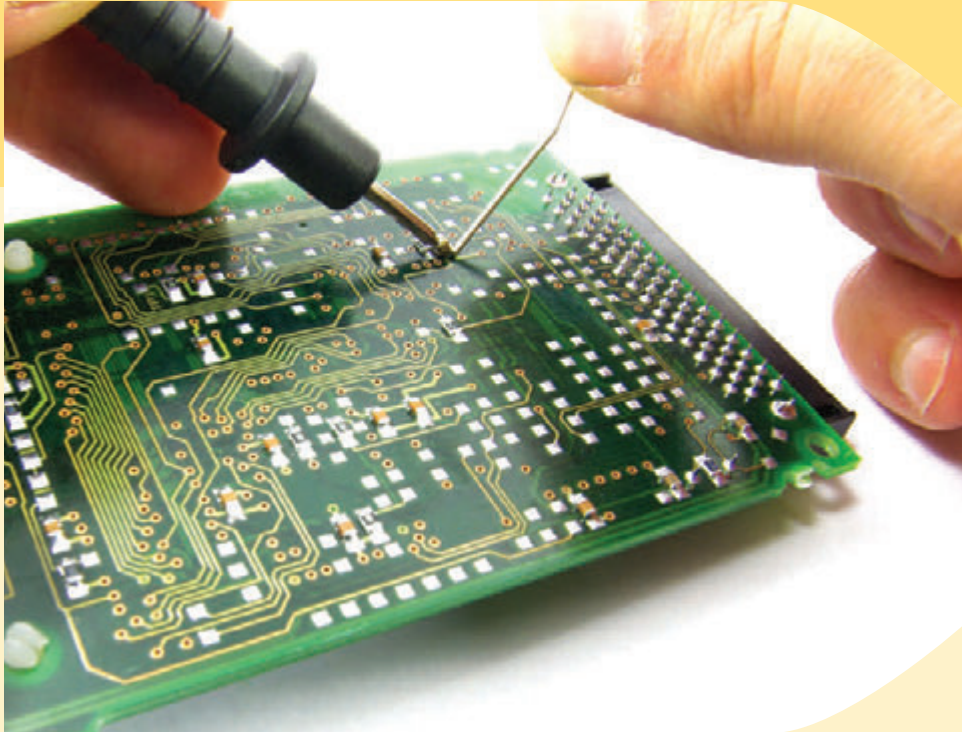

Figure P27.85

Direct-Current Circuits

CHAPTER

28



- 28.1 Electromotive Force
- 28.2 Resistors in Series and Parallel
- 28.3 Kirchhoff's Rules
- 28.4 RC Circuits
- 28.5 Household Wiring and Electrical Safety

In this chapter, we analyze simple electric circuits that contain batteries, resistors, and capacitors in various combinations. Some circuits contain resistors that can be combined using simple rules. The analysis of more complicated circuits is simplified using *Kirchhoff's rules*, which follow from the laws of conservation of energy and conservation of electric charge for isolated systems. Most of the circuits analyzed are assumed to be in *steady state*, which means that currents in the circuit are constant in magnitude and direction. A current that is constant in direction is called a *direct current* (DC). We will study *alternating current* (AC), in which the current changes direction periodically, in Chapter 33. Finally, we discuss electrical circuits in the home.

A technician repairs a connection on a circuit board from a computer. In our lives today, we use various items containing electric circuits, including many with circuit boards much smaller than the board shown in the photograph. These include handheld game players, cell phones, and digital cameras. In this chapter, we study simple types of circuits and learn how to analyze them.

(Trombax/Shutterstock.com)

28.1 Electromotive Force

In Section 27.6, we discussed a circuit in which a battery produces a current. We will generally use a battery as a source of energy for circuits in our discussion. Because the potential difference at the battery terminals is constant in a particular circuit, the current in the circuit is constant in magnitude and direction and is called **direct current**. A battery is called either a *source of electromotive force* or, more commonly, a *source of emf*. (The phrase *electromotive force* is an unfortunate historical term, describing not a force, but rather a potential difference in volts.) The **emf \mathcal{E}** of a battery is **the maximum possible voltage the battery can provide between its terminals**. You can think of a source of emf as a “charge pump.” When an electric potential difference exists between two points, the source moves charges “uphill” from the lower potential to the higher.

We shall generally assume the connecting wires in a circuit have no resistance. The positive terminal of a battery is at a higher potential than the negative terminal.

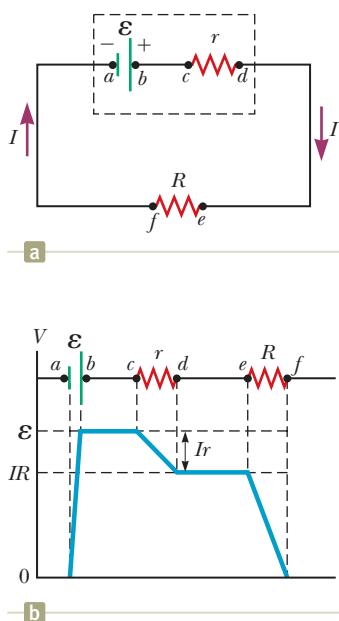

Figure 28.1 (a) Circuit diagram of a source of emf \mathcal{E} (in this case, a battery), of internal resistance r , connected to an external resistor of resistance R . (b) Graphical representation showing how the electric potential changes as the circuit in (a) is traversed clockwise.

Because a real battery is made of matter, there is resistance to the flow of charge within the battery. This resistance is called **internal resistance** r . For an idealized battery with zero internal resistance, the potential difference across the battery (called its *terminal voltage*) equals its emf. For a real battery, however, the terminal voltage is *not* equal to the emf for a battery in a circuit in which there is a current. To understand why, consider the circuit diagram in Figure 28.1a. We model the battery as shown in the diagram; it is represented by the dashed rectangle containing an ideal, resistance-free emf \mathcal{E} in series with an internal resistance r . A resistor of resistance R is connected across the terminals of the battery. Now imagine moving through the battery from a to d and measuring the electric potential at various locations. Passing from the negative terminal to the positive terminal, the potential increases by an amount \mathcal{E} . As we move through the resistance r , however, the potential *decreases* by an amount Ir , where I is the current in the circuit. Therefore, the terminal voltage of the battery $\Delta V = V_d - V_a$ is

$$\Delta V = \mathcal{E} - Ir \quad (28.1)$$

From this expression, notice that \mathcal{E} is equivalent to the **open-circuit voltage**, that is, the terminal voltage when the current is zero. The emf is the voltage labeled on a battery; for example, the emf of a D cell is 1.5 V. The actual potential difference between a battery's terminals depends on the current in the battery as described by Equation 28.1. Figure 28.1b is a graphical representation of the changes in electric potential as the circuit is traversed in the clockwise direction.

Figure 28.1a shows that the terminal voltage ΔV must equal the potential difference across the external resistance R , often called the **load resistance**. The load resistor might be a simple resistive circuit element as in Figure 28.1a, or it could be the resistance of some electrical device (such as a toaster, electric heater, or lightbulb) connected to the battery (or, in the case of household devices, to the wall outlet). The resistor represents a *load* on the battery because the battery must supply energy to operate the device containing the resistance. The potential difference across the load resistance is $\Delta V = IR$. Combining this expression with Equation 28.1, we see that

$$\mathcal{E} = IR + Ir \quad (28.2)$$

Figure 28.1a shows a graphical representation of this equation. Solving for the current gives

$$I = \frac{\mathcal{E}}{R + r} \quad (28.3)$$

Equation 28.3 shows that the current in this simple circuit depends on both the load resistance R external to the battery and the internal resistance r . If R is much greater than r , as it is in many real-world circuits, we can neglect r .

Multiplying Equation 28.2 by the current I in the circuit gives

$$I\mathcal{E} = I^2R + I^2r \quad (28.4)$$

Equation 28.4 indicates that because power $P = I\Delta V$ (see Eq. 27.21), the total power output $I\mathcal{E}$ associated with the emf of the battery is delivered to the external load resistance in the amount I^2R and to the internal resistance in the amount I^2r .

Quick Quiz 28.1 To maximize the percentage of the power from the emf of a battery that is delivered to a device external to the battery, what should the internal resistance of the battery be? (a) It should be as low as possible. (b) It should be as high as possible. (c) The percentage does not depend on the internal resistance.

Pitfall Prevention 28.1

What Is Constant in a Battery?

It is a common misconception that a battery is a source of constant current. Equation 28.3 shows that is not true. The current in the circuit depends on the resistance R connected to the battery. It is also not true that a battery is a source of constant terminal voltage as shown by Equation 28.1. **A battery is a source of constant emf.**

Example 28.1

Terminal Voltage of a Battery

A battery has an emf of 12.0 V and an internal resistance of $0.050 \, \Omega$. Its terminals are connected to a load resistance of $3.00 \, \Omega$.

▶ 28.1 continued

(A) Find the current in the circuit and the terminal voltage of the battery.

SOLUTION

Conceptualize Study Figure 28.1a, which shows a circuit consistent with the problem statement. The battery delivers energy to the load resistor.

Categorize This example involves simple calculations from this section, so we categorize it as a substitution problem.

Use Equation 28.3 to find the current in the circuit:

$$I = \frac{\mathcal{E}}{R + r} = \frac{12.0 \text{ V}}{3.00 \Omega + 0.0500 \Omega} = 3.93 \text{ A}$$

Use Equation 28.1 to find the terminal voltage:

$$\Delta V = \mathcal{E} - Ir = 12.0 \text{ V} - (3.93 \text{ A})(0.0500 \Omega) = 11.8 \text{ V}$$

To check this result, calculate the voltage across the load resistance R :

$$\Delta V = IR = (3.93 \text{ A})(3.00 \Omega) = 11.8 \text{ V}$$

(B) Calculate the power delivered to the load resistor, the power delivered to the internal resistance of the battery, and the power delivered by the battery.

SOLUTION

Use Equation 27.22 to find the power delivered to the load resistor:

$$P_R = I^2R = (3.93 \text{ A})^2(3.00 \Omega) = 46.3 \text{ W}$$

Find the power delivered to the internal resistance:

$$P_r = I^2r = (3.93 \text{ A})^2(0.0500 \Omega) = 0.772 \text{ W}$$

Find the power delivered by the battery by adding these quantities:

$$P = P_R + P_r = 46.3 \text{ W} + 0.772 \text{ W} = 47.1 \text{ W}$$

WHAT IF? As a battery ages, its internal resistance increases. Suppose the internal resistance of this battery rises to 2.00Ω toward the end of its useful life. How does that alter the battery's ability to deliver energy?

Answer Let's connect the same $3.00\text{-}\Omega$ load resistor to the battery.

Find the new current in the battery:

$$I = \frac{\mathcal{E}}{R + r} = \frac{12.0 \text{ V}}{3.00 \Omega + 2.00 \Omega} = 2.40 \text{ A}$$

Find the new terminal voltage:

$$\Delta V = \mathcal{E} - Ir = 12.0 \text{ V} - (2.40 \text{ A})(2.00 \Omega) = 7.2 \text{ V}$$

Find the new powers delivered to the load resistor and internal resistance:

$$P_R = I^2R = (2.40 \text{ A})^2(3.00 \Omega) = 17.3 \text{ W}$$

$$P_r = I^2r = (2.40 \text{ A})^2(2.00 \Omega) = 11.5 \text{ W}$$

In this situation, the terminal voltage is only 60% of the emf. Notice that 40% of the power from the battery is delivered to the internal resistance when r is 2.00Ω . When r is 0.0500Ω as in part (B), this percentage is only 1.6%. Consequently, even though the emf remains fixed, the increasing internal resistance of the battery significantly reduces the battery's ability to deliver energy to an external load.

Example 28.2 Matching the Load

Find the load resistance R for which the maximum power is delivered to the load resistance in Figure 28.1a.

SOLUTION

Conceptualize Think about varying the load resistance in Figure 28.1a and the effect on the power delivered to the load resistance. When R is large, there is very little current, so the power I^2R delivered to the load resistor is small.

continued

28.2 continued

When R is small, let's say $R \ll r$, the current is large and the power delivered to the internal resistance is $I^2 r \gg I^2 R$. Therefore, the power delivered to the load resistor is small compared to that delivered to the internal resistance. For some intermediate value of the resistance R , the power must maximize.

Categorize We categorize this example as an analysis problem because we must undertake a procedure to maximize the power. The circuit is the same as that in Example 28.1. The load resistance R in this case, however, is a variable.

Analyze Find the power delivered to the load resistance using Equation 27.22, with I given by Equation 28.3:

Differentiate the power with respect to the load resistance R and set the derivative equal to zero to maximize the power:

Solve for R :

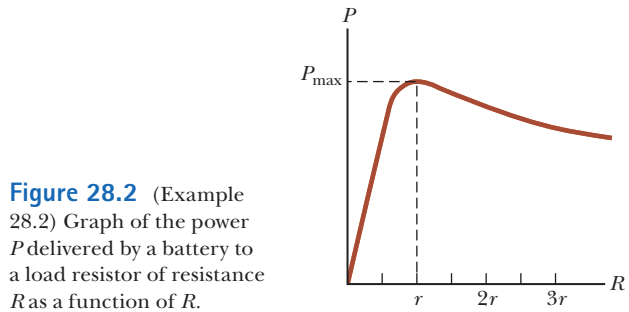

Figure 28.2 (Example 28.2) Graph of the power P delivered by a battery to a load resistor of resistance R as a function of R .

$$(1) \quad P = I^2 R = \frac{\mathcal{E}^2 R}{(R + r)^2}$$

$$\frac{dP}{dR} = \frac{d}{dR} \left[\frac{\mathcal{E}^2 R}{(R + r)^2} \right] = \frac{d}{dR} [\mathcal{E}^2 R (R + r)^{-2}] = 0$$

$$[\mathcal{E}^2 (R + r)^{-2}] + [\mathcal{E}^2 R (-2)(R + r)^{-3}] = 0$$

$$\frac{\mathcal{E}^2 (R + r)}{(R + r)^3} - \frac{2\mathcal{E}^2 R}{(R + r)^3} = \frac{\mathcal{E}^2 (r - R)}{(R + r)^3} = 0$$

$$R = r$$

Finalize To check this result, let's plot P versus R as in Figure 28.2. The graph shows that P reaches a maximum value at $R = r$. Equation (1) shows that this maximum value is $P_{\max} = \mathcal{E}^2/4r$.

28.2 Resistors in Series and Parallel

When two or more resistors are connected together as are the incandescent lightbulbs in Figure 28.3a, they are said to be in a **series combination**. Figure 28.3b is the circuit diagram for the lightbulbs, shown as resistors, and the battery. What if you wanted to replace the series combination with a single resistor that would draw the same current from the battery? What would be its value? In a series connection, if an amount of charge Q exits resistor R_1 , charge Q must also enter the second resistor R_2 . Otherwise, charge would accumulate on the wire between the resistors. Therefore, the same amount of charge passes through both resistors in a given time interval and the currents are the same in both resistors:

$$I = I_1 = I_2$$

where I is the current leaving the battery, I_1 is the current in resistor R_1 , and I_2 is the current in resistor R_2 .

The potential difference applied across the series combination of resistors divides between the resistors. In Figure 28.3b, because the voltage drop¹ from a to b equals $I_1 R_1$ and the voltage drop from b to c equals $I_2 R_2$, the voltage drop from a to c is

$$\Delta V = \Delta V_1 + \Delta V_2 = I_1 R_1 + I_2 R_2$$

The potential difference across the battery is also applied to the **equivalent resistance** R_{eq} in Figure 28.3c:

$$\Delta V = I R_{\text{eq}}$$

¹The term *voltage drop* is synonymous with a decrease in electric potential across a resistor. It is often used by individuals working with electric circuits.

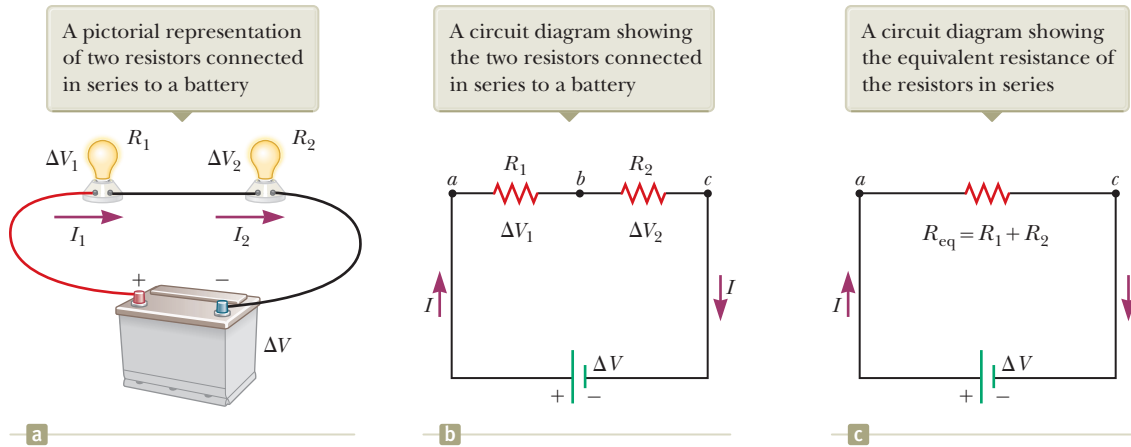

Figure 28.3 Two lightbulbs with resistances R_1 and R_2 connected in series. All three diagrams are equivalent.

where the equivalent resistance has the same effect on the circuit as the series combination because it results in the same current I in the battery. Combining these equations for ΔV gives

$$IR_{\text{eq}} = I_1R_1 + I_2R_2 \rightarrow R_{\text{eq}} = R_1 + R_2 \quad (28.5)$$

where we have canceled the currents I , I_1 , and I_2 because they are all the same. We see that we can replace the two resistors in series with a single equivalent resistance whose value is the *sum* of the individual resistances.

The equivalent resistance of three or more resistors connected in series is

$$R_{\text{eq}} = R_1 + R_2 + R_3 + \cdots \quad (28.6)$$

This relationship indicates that the equivalent resistance of a series combination of resistors is the numerical sum of the individual resistances and is always greater than any individual resistance.

Looking back at Equation 28.3, we see that the denominator of the right-hand side is the simple algebraic sum of the external and internal resistances. That is consistent with the internal and external resistances being in series in Figure 28.1a.

If the filament of one lightbulb in Figure 28.3 were to fail, the circuit would no longer be complete (resulting in an open-circuit condition) and the second lightbulb would also go out. This fact is a general feature of a series circuit: if one device in the series creates an open circuit, all devices are inoperative.

Quick Quiz 28.2 With the switch in the circuit of Figure 28.4a closed, there is no current in R_2 because the current has an alternate zero-resistance path through the switch. There is current in R_1 , and this current is measured with the ammeter (a device for measuring current) at the bottom of the circuit. If the switch is opened (Fig. 28.4b), there is current in R_2 . What happens to the reading on the ammeter when the switch is opened? (a) The reading goes up. (b) The reading goes down. (c) The reading does not change.

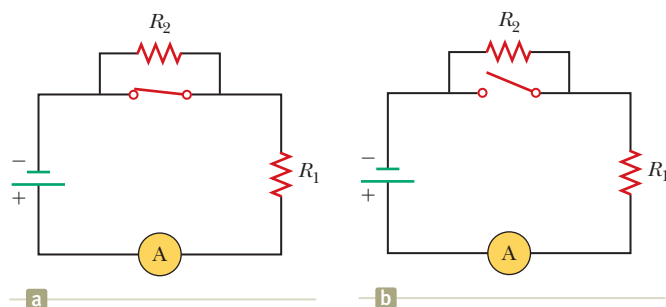

Figure 28.4 (Quick Quiz 28.2) What happens when the switch is opened?

◀ The equivalent resistance of a series combination of resistors

Pitfall Prevention 28.2

Lightbulbs Don't Burn We will describe the end of the life of an incandescent lightbulb by saying *the filament fails* rather than by saying the lightbulb “burns out.” The word *burn* suggests a combustion process, which is not what occurs in a lightbulb. The failure of a lightbulb results from the slow sublimation of tungsten from the very hot filament over the life of the lightbulb. The filament eventually becomes very thin because of this process. The mechanical stress from a sudden temperature increase when the lightbulb is turned on causes the thin filament to break.

Pitfall Prevention 28.3

Local and Global Changes A *local change in one part of a circuit may result in a global change throughout the circuit*. For example, if a single resistor is changed in a circuit containing several resistors and batteries, the currents in all resistors and batteries, the terminal voltages of all batteries, and the voltages across all resistors may change as a result.

Figure 28.5 Two lightbulbs with resistances R_1 and R_2 connected in parallel. All three diagrams are equivalent.

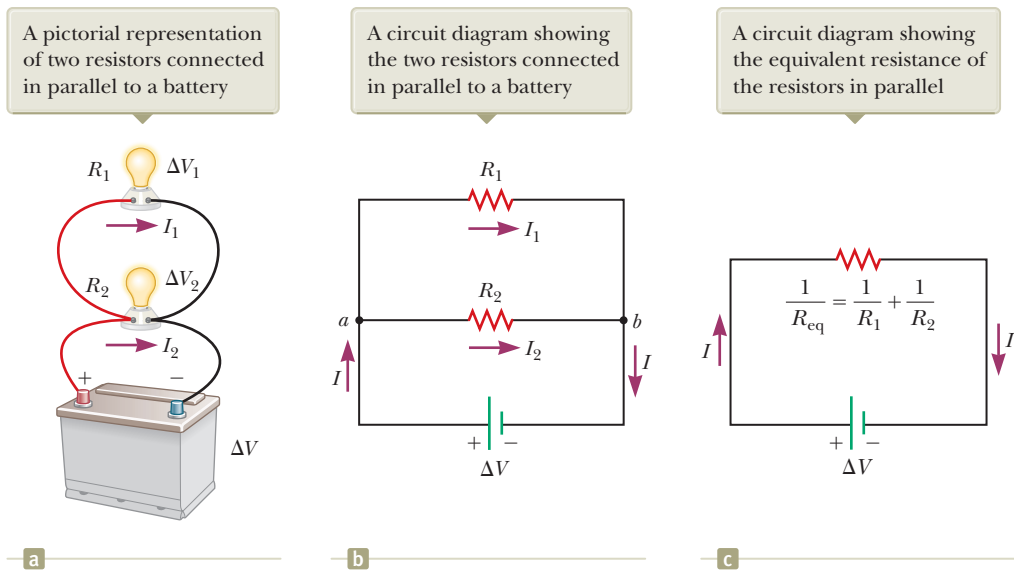

Pitfall Prevention 28.4

Current Does Not Take the Path of Least Resistance You may have heard the phrase “current takes the path of least resistance” (or similar wording) in reference to a parallel combination of current paths such that there are two or more paths for the current to take. Such wording is incorrect. The current takes *all* paths. Those paths with lower resistance have larger currents, but even very high resistance paths carry *some* of the current. In theory, if current has a choice between a zero-resistance path and a finite resistance path, all the current takes the path of zero resistance; a path with zero resistance, however, is an idealization.

Now consider two resistors in a **parallel combination** as shown in Figure 28.5. As with the series combination, what is the value of the single resistor that could replace the combination and draw the same current from the battery? Notice that both resistors are connected directly across the terminals of the battery. Therefore, the potential differences across the resistors are the same:

$$\Delta V = \Delta V_1 = \Delta V_2$$

where ΔV is the terminal voltage of the battery.

When charges reach point a in Figure 28.5b, they split into two parts, with some going toward R_1 and the rest going toward R_2 . A **junction** is any such point in a circuit where a current can split. This split results in less current in each individual resistor than the current leaving the battery. Because electric charge is conserved, the current I that enters point a must equal the total current leaving that point:

$$I = I_1 + I_2 = \frac{\Delta V_1}{R_1} + \frac{\Delta V_2}{R_2}$$

where I_1 is the current in R_1 and I_2 is the current in R_2 .

The current in the **equivalent resistance** R_{eq} in Figure 28.5c is

$$I = \frac{\Delta V}{R_{\text{eq}}}$$

where the equivalent resistance has the same effect on the circuit as the two resistors in parallel; that is, the equivalent resistance draws the same current I from the battery. Combining these equations for I , we see that the equivalent resistance of two resistors in parallel is given by

$$\frac{\Delta V}{R_{\text{eq}}} = \frac{\Delta V_1}{R_1} + \frac{\Delta V_2}{R_2} \rightarrow \frac{1}{R_{\text{eq}}} = \frac{1}{R_1} + \frac{1}{R_2} \quad (28.7)$$

where we have canceled ΔV , ΔV_1 , and ΔV_2 because they are all the same.

An extension of this analysis to three or more resistors in parallel gives

$$\frac{1}{R_{\text{eq}}} = \frac{1}{R_1} + \frac{1}{R_2} + \frac{1}{R_3} + \cdots \quad (28.8)$$

This expression shows that the inverse of the equivalent resistance of two or more resistors in a parallel combination is equal to the sum of the inverses of the indi-

The equivalent resistance of a parallel combination of resistors

vidual resistances. Furthermore, the equivalent resistance is always less than the smallest resistance in the group.

Household circuits are always wired such that the appliances are connected in parallel. Each device operates independently of the others so that if one is switched off, the others remain on. In addition, in this type of connection, all the devices operate on the same voltage.

Let's consider two examples of practical applications of series and parallel circuits. Figure 28.6 illustrates how a three-way incandescent lightbulb is constructed to provide three levels of light intensity.² The socket of the lamp is equipped with a three-way switch for selecting different light intensities. The lightbulb contains two filaments. When the lamp is connected to a 120-V source, one filament receives 100 W of power and the other receives 75 W. The three light intensities are made possible by applying the 120 V to one filament alone, to the other filament alone, or to the two filaments in parallel. When switch S_1 is closed and switch S_2 is opened, current exists only in the 75-W filament. When switch S_1 is open and switch S_2 is closed, current exists only in the 100-W filament. When both switches are closed, current exists in both filaments and the total power is 175 W.

If the filaments were connected in series and one of them were to break, no charges could pass through the lightbulb and it would not glow, regardless of the switch position. If, however, the filaments were connected in parallel and one of them (for example, the 75-W filament) were to break, the lightbulb would continue to glow in two of the switch positions because current exists in the other (100-W) filament.

As a second example, consider strings of incandescent lights that are used for many ornamental purposes such as decorating Christmas trees. Over the years, both parallel and series connections have been used for strings of lights. Because series-wired lightbulbs operate with less energy per bulb and at a lower temperature, they are safer than parallel-wired lightbulbs for indoor Christmas-tree use. If, however, the filament of a single lightbulb in a series-wired string were to fail (or if the lightbulb were removed from its socket), all the lights on the string would go out. The popularity of series-wired light strings diminished because troubleshooting a failed lightbulb is a tedious, time-consuming chore that involves trial-and-error substitution of a good lightbulb in each socket along the string until the defective one is found.

In a parallel-wired string, each lightbulb operates at 120 V. By design, the lightbulbs are brighter and hotter than those on a series-wired string. As a result, they are inherently more dangerous (more likely to start a fire, for instance), but if one lightbulb in a parallel-wired string fails or is removed, the rest of the lightbulbs continue to glow.

To prevent the failure of one lightbulb from causing the entire string to go out, a new design was developed for so-called miniature lights wired in series. When the filament breaks in one of these miniature lightbulbs, the break in the filament represents the largest resistance in the series, much larger than that of the intact filaments. As a result, most of the applied 120 V appears across the lightbulb with the broken filament. Inside the lightbulb, a small jumper loop covered by an insulating material is wrapped around the filament leads. When the filament fails and 120 V appears across the lightbulb, an arc burns the insulation on the jumper and connects the filament leads. This connection now completes the circuit through the lightbulb even though its filament is no longer active (Fig. 28.7, page 840).

When a lightbulb fails, the resistance across its terminals is reduced to almost zero because of the alternate jumper connection mentioned in the preceding paragraph. All the other lightbulbs not only stay on, but they glow more brightly because

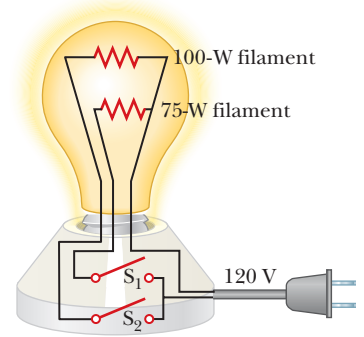

Figure 28.6 A three-way incandescent lightbulb.

²The three-way lightbulb and other household devices actually operate on alternating current (AC), to be introduced in Chapter 33.

Figure 28.7 (a) Schematic diagram of a modern “miniature” incandescent holiday lightbulb, with a jumper connection to provide a current path if the filament breaks. (b) A holiday lightbulb with a broken filament. (c) A Christmas-tree lightbulb.

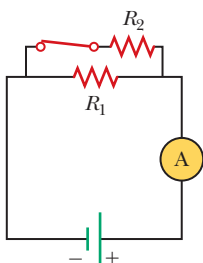
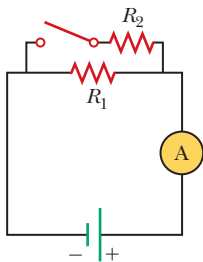
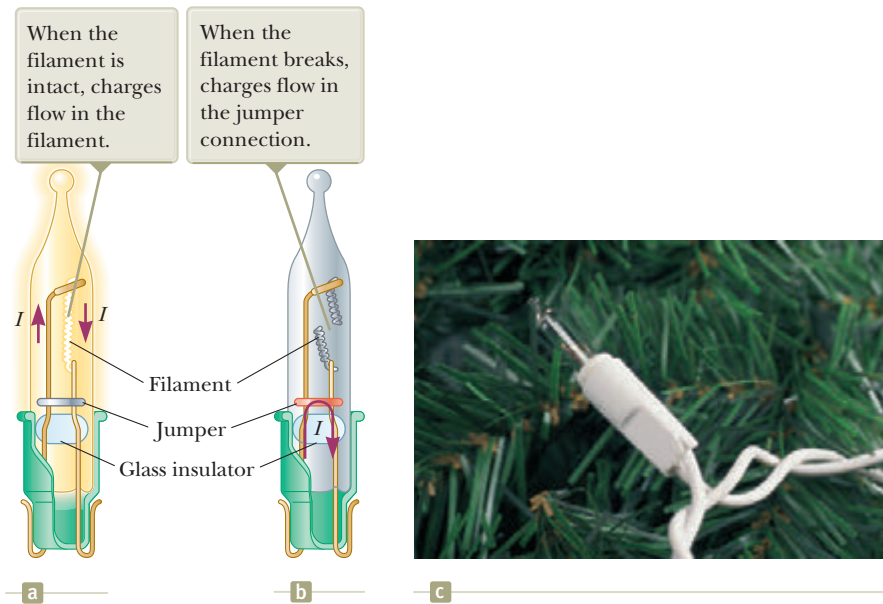

Figure 28.8 (Quick Quiz 28.3) What happens when the switch is closed?

the total resistance of the string is reduced and consequently the current in each remaining lightbulb increases. Each lightbulb operates at a slightly higher temperature than before. As more lightbulbs fail, the current keeps rising, the filament of each remaining lightbulb operates at a higher temperature, and the lifetime of the lightbulb is reduced. For this reason, you should check for failed (nonglowing) lightbulbs in such a series-wired string and replace them as soon as possible, thereby maximizing the lifetimes of all the lightbulbs.

Quick Quiz 28.3 With the switch in the circuit of Figure 28.8a open, there is no current in R_2 . There is current in R_1 , however, and it is measured with the ammeter at the right side of the circuit. If the switch is closed (Fig. 28.8b), there is current in R_2 . What happens to the reading on the ammeter when the switch is closed? (a) The reading increases. (b) The reading decreases. (c) The reading does not change.

Quick Quiz 28.4 Consider the following choices: (a) increases, (b) decreases, (c) remains the same. From these choices, choose the best answer for the following situations. (i) In Figure 28.3, a third resistor is added in series with the first two. What happens to the current in the battery? (ii) What happens to the terminal voltage of the battery? (iii) In Figure 28.5, a third resistor is added in parallel with the first two. What happens to the current in the battery? (iv) What happens to the terminal voltage of the battery?

Conceptual Example 28.3

Landscape Lights

A homeowner wishes to install low-voltage landscape lighting in his back yard. To save money, he purchases inexpensive 18-gauge cable, which has a relatively high resistance per unit length. This cable consists of two side-by-side wires separated by insulation, like the cord on an appliance. He runs a 200-foot length of this cable from the power supply to the farthest point at which he plans to position a light fixture. He attaches light fixtures across the two wires on the cable at 10-foot intervals so that the light fixtures are in parallel. Because of the cable's resistance, the brightness of the lightbulbs in the fixtures is not as desired. Which of the following problems does the homeowner have? (a) All the lightbulbs glow equally less brightly than they would if lower-resistance cable had been used. (b) The brightness of the lightbulbs decreases as you move farther from the power supply.

28.3 continued

SOLUTION

A circuit diagram for the system appears in Figure 28.9. The horizontal resistors with letter subscripts (such as R_A) represent the resistance of the wires in the cable between the light fixtures, and the vertical resistors with number subscripts (such as R_1) represent the resistance of the light fixtures themselves. Part of the terminal voltage of the power supply is dropped across resistors R_A and R_B . Therefore, the voltage across light fixture R_1 is less than the terminal voltage. There is a further voltage drop across resistors R_C and R_D . Consequently, the voltage across light fixture R_2 is smaller than that across R_1 . This pattern continues down the line of light fixtures, so the correct choice is (b). Each successive light fixture has a smaller voltage across it and glows less brightly than the one before.

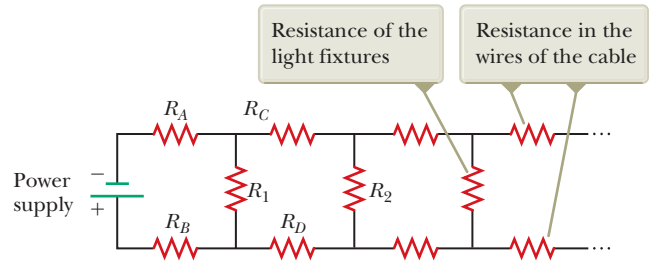

Figure 28.9 (Conceptual Example 28.3) The circuit diagram for a set of landscape light fixtures connected in parallel across the two wires of a two-wire cable.

Example 28.4 Find the Equivalent Resistance

Four resistors are connected as shown in Figure 28.10a.

(A) Find the equivalent resistance between points a and c .

SOLUTION

Conceptualize Imagine charges flowing into and through this combination from the left. All charges must pass from a to b through the first two resistors, but the charges split at b into two different paths when encountering the combination of the $6.0\text{-}\Omega$ and the $3.0\text{-}\Omega$ resistors.

Categorize Because of the simple nature of the combination of resistors in Figure 28.10, we categorize this example as one for which we can use the rules for series and parallel combinations of resistors.

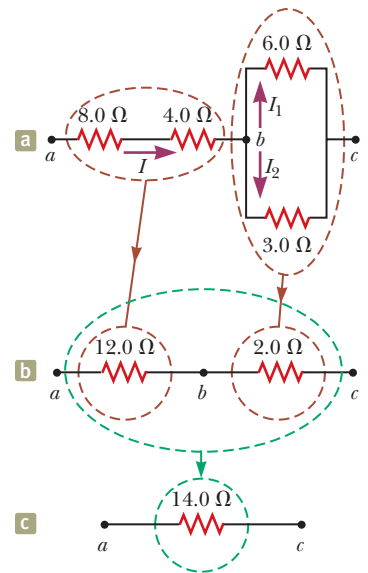

Figure 28.10 (Example 28.4) The original network of resistors is reduced to a single equivalent resistance.

Analyze The combination of resistors can be reduced in steps as shown in Figure 28.10.

Find the equivalent resistance between a and b of the $8.0\text{-}\Omega$ and $4.0\text{-}\Omega$ resistors, which are in series (left-hand red-brown circles):

$$R_{eq} = 8.0\ \Omega + 4.0\ \Omega = 12.0\ \Omega$$

Find the equivalent resistance between b and c of the $6.0\text{-}\Omega$ and $3.0\text{-}\Omega$ resistors, which are in parallel (right-hand red-brown circles):

$$\frac{1}{R_{eq}} = \frac{1}{6.0\ \Omega} + \frac{1}{3.0\ \Omega} = \frac{3}{6.0\ \Omega}$$

$$R_{eq} = \frac{6.0\ \Omega}{3} = 2.0\ \Omega$$

The circuit of equivalent resistances now looks like Figure 28.10b. The $12.0\text{-}\Omega$ and $2.0\text{-}\Omega$ resistors are in series (green circles). Find the equivalent resistance from a to c :

$$R_{eq} = 12.0\ \Omega + 2.0\ \Omega = 14.0\ \Omega$$

This resistance is that of the single equivalent resistor in Figure 28.10c.

(B) What is the current in each resistor if a potential difference of 42 V is maintained between a and c ?

continued

28.4 continued

SOLUTION

The currents in the 8.0- Ω and 4.0- Ω resistors are the same because they are in series. In addition, they carry the same current that would exist in the 14.0- Ω equivalent resistor subject to the 42-V potential difference.

Use Equation 27.7 ($R = \Delta V/I$) and the result from part (A) to find the current in the 8.0- Ω and 4.0- Ω resistors:

$$I = \frac{\Delta V_{ac}}{R_{eq}} = \frac{42 \text{ V}}{14.0 \Omega} = 3.0 \text{ A}$$

Set the voltages across the resistors in parallel in Figure 28.10a equal to find a relationship between the currents:

$$\Delta V_1 = \Delta V_2 \rightarrow (6.0 \Omega)I_1 = (3.0 \Omega)I_2 \rightarrow I_2 = 2I_1$$

Use $I_1 + I_2 = 3.0 \text{ A}$ to find I_1 :

$$I_1 + I_2 = 3.0 \text{ A} \rightarrow I_1 + 2I_1 = 3.0 \text{ A} \rightarrow I_1 = 1.0 \text{ A}$$

Find I_2 :

$$I_2 = 2I_1 = 2(1.0 \text{ A}) = 2.0 \text{ A}$$

Finalize As a final check of our results, note that $\Delta V_{bc} = (6.0 \Omega)I_1 = (3.0 \Omega)I_2 = 6.0 \text{ V}$ and $\Delta V_{ab} = (12.0 \Omega)I = 36 \text{ V}$; therefore, $\Delta V_{ac} = \Delta V_{ab} + \Delta V_{bc} = 42 \text{ V}$, as it must.

Example 28.5 Three Resistors in Parallel

Three resistors are connected in parallel as shown in Figure 28.11a. A potential difference of 18.0 V is maintained between points a and b .

(A) Calculate the equivalent resistance of the circuit.

SOLUTION

Conceptualize Figure 28.11a shows that we are dealing with a simple parallel combination of three resistors. Notice that the current I splits into three currents I_1 , I_2 , and I_3 in the three resistors.

Categorize This problem can be solved with rules developed in this section, so we categorize it as a substitution problem. Because the three resistors are connected in parallel, we can use the rule for resistors in parallel, Equation 28.8, to evaluate the equivalent resistance.

Use Equation 28.8 to find R_{eq} :

$$\frac{1}{R_{eq}} = \frac{1}{3.00 \Omega} + \frac{1}{6.00 \Omega} + \frac{1}{9.00 \Omega} = \frac{11}{18.0}$$

$$R_{eq} = \frac{18.0 \Omega}{11} = 1.64 \Omega$$

(B) Find the current in each resistor.

SOLUTION

The potential difference across each resistor is 18.0 V. Apply the relationship $\Delta V = IR$ to find the currents:

$$I_1 = \frac{\Delta V}{R_1} = \frac{18.0 \text{ V}}{3.00 \Omega} = 6.00 \text{ A}$$

$$I_2 = \frac{\Delta V}{R_2} = \frac{18.0 \text{ V}}{6.00 \Omega} = 3.00 \text{ A}$$

$$I_3 = \frac{\Delta V}{R_3} = \frac{18.0 \text{ V}}{9.00 \Omega} = 2.00 \text{ A}$$

(C) Calculate the power delivered to each resistor and the total power delivered to the combination of resistors.

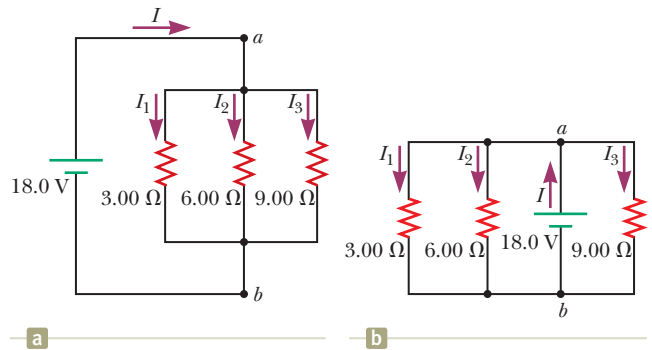

Figure 28.11 (Example 28.5) (a) Three resistors connected in parallel. The voltage across each resistor is 18.0 V. (b) Another circuit with three resistors and a battery. Is it equivalent to the circuit in (a)?

► 28.5 continued

SOLUTION

Apply the relationship $P = I^2R$ to each resistor using the currents calculated in part (B):

$$3.00\text{-}\Omega: P_1 = I_1^2R_1 = (6.00\text{ A})^2(3.00\ \Omega) = 108\text{ W}$$

$$6.00\text{-}\Omega: P_2 = I_2^2R_2 = (3.00\text{ A})^2(6.00\ \Omega) = 54\text{ W}$$

$$9.00\text{-}\Omega: P_3 = I_3^2R_3 = (2.00\text{ A})^2(9.00\ \Omega) = 36\text{ W}$$

These results show that the smallest resistor receives the most power. Summing the three quantities gives a total power of 198 W. We could have calculated this final result from part (A) by considering the equivalent resistance as follows: $P = (\Delta V)^2/R_{\text{eq}} = (18.0\text{ V})^2/1.64\ \Omega = 198\text{ W}$.

WHAT IF? What if the circuit were as shown in Figure 28.11b instead of as in Figure 28.11a? How would that affect the calculation?

Answer There would be no effect on the calculation. The physical placement of the battery is not important. Only the electrical arrangement is important. In Figure 28.11b, the battery still maintains a potential difference of 18.0 V between points *a* and *b*, so the two circuits in the figure are electrically identical.

28.3 Kirchhoff's Rules

As we saw in the preceding section, combinations of resistors can be simplified and analyzed using the expression $\Delta V = IR$ and the rules for series and parallel combinations of resistors. Very often, however, it is not possible to reduce a circuit to a single loop using these rules. The procedure for analyzing more complex circuits is made possible by using the following two principles, called **Kirchhoff's rules**.

1. Junction rule. At any junction, the sum of the currents must equal zero:

$$\sum_{\text{junction}} I = 0 \quad (28.9)$$

2. Loop rule. The sum of the potential differences across all elements around any closed circuit loop must be zero:

$$\sum_{\text{closed loop}} \Delta V = 0 \quad (28.10)$$

Kirchhoff's first rule is a statement of conservation of electric charge. All charges that enter a given point in a circuit must leave that point because charge cannot build up or disappear at a point. Currents directed into the junction are entered into the sum in the junction rule as $+I$, whereas currents directed out of a junction are entered as $-I$. Applying this rule to the junction in Figure 28.12a gives

$$I_1 - I_2 - I_3 = 0$$

Figure 28.12b represents a mechanical analog of this situation, in which water flows through a branched pipe having no leaks. Because water does not build up anywhere in the pipe, the flow rate into the pipe on the left equals the total flow rate out of the two branches on the right.

Kirchhoff's second rule follows from the law of conservation of energy for an isolated system. Let's imagine moving a charge around a closed loop of a circuit. When the charge returns to the starting point, the charge-circuit system must have the same total energy as it had before the charge was moved. The sum of the increases in energy as the charge passes through some circuit elements must equal the sum of the decreases in energy as it passes through other elements. The potential energy of the system decreases whenever the charge moves through a potential drop $-IR$ across a resistor or whenever it moves in the reverse direction through a

The amount of charge flowing out of the branches on the right must equal the amount flowing into the single branch on the left.

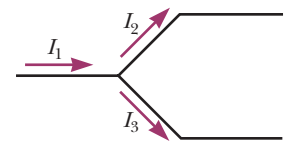

a

The amount of water flowing out of the branches on the right must equal the amount flowing into the single branch on the left.

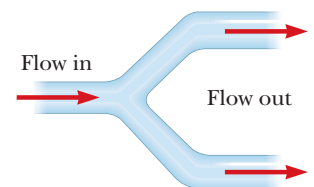

b

Figure 28.12 (a) Kirchhoff's junction rule. (b) A mechanical analog of the junction rule.

In each diagram, $\Delta V = V_b - V_a$ and the circuit element is traversed from a to b , left to right.

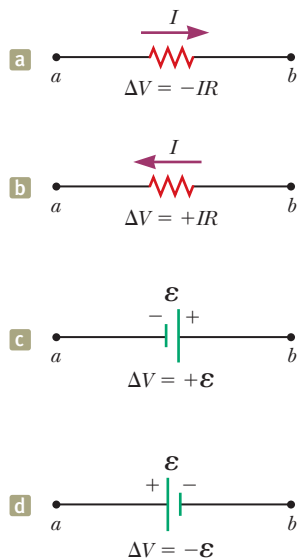

Figure 28.13 Rules for determining the signs of the potential differences across a resistor and a battery. (The battery is assumed to have no internal resistance.)

source of emf. The potential energy increases whenever the charge passes through a battery from the negative terminal to the positive terminal.

When applying Kirchhoff's second rule, imagine *traveling* around the loop and consider changes in *electric potential* rather than the changes in *potential energy* described in the preceding paragraph. Imagine traveling through the circuit elements in Figure 28.13 toward the right. The following sign conventions apply when using the second rule:

- Charges move from the high-potential end of a resistor toward the low-potential end, so if a resistor is traversed in the direction of the current, the potential difference ΔV across the resistor is $-IR$ (Fig. 28.13a).
- If a resistor is traversed in the direction *opposite* the current, the potential difference ΔV across the resistor is $+IR$ (Fig. 28.13b).
- If a source of emf (assumed to have zero internal resistance) is traversed in the direction of the emf (from negative to positive), the potential difference ΔV is $+\epsilon$ (Fig. 28.13c).
- If a source of emf (assumed to have zero internal resistance) is traversed in the direction opposite the emf (from positive to negative), the potential difference ΔV is $-\epsilon$ (Fig. 28.13d).

There are limits on the number of times you can usefully apply Kirchhoff's rules in analyzing a circuit. You can use the junction rule as often as you need as long as you include in it a current that has not been used in a preceding junction-rule equation. In general, the number of times you can use the junction rule is one fewer than the number of junction points in the circuit. You can apply the loop rule as often as needed as long as a new circuit element (resistor or battery) or a new current appears in each new equation. In general, to solve a particular circuit problem, the number of independent equations you need to obtain from the two rules equals the number of unknown currents.

Complex networks containing many loops and junctions generate a great number of independent linear equations and a correspondingly great number of unknowns. Such situations can be handled formally through the use of matrix algebra. Computer software can also be used to solve for the unknowns.

The following examples illustrate how to use Kirchhoff's rules. In all cases, it is assumed the circuits have reached steady-state conditions; in other words, the currents in the various branches are constant. Any capacitor acts as an open branch in a circuit; that is, the current in the branch containing the capacitor is zero under steady-state conditions.

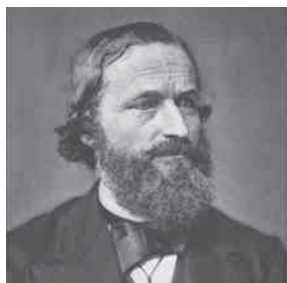

Prints & Photographs Division, Library of Congress, LC-USZ62-133715

Gustav Kirchhoff

German Physicist (1824–1887)

Kirchhoff, a professor at Heidelberg, and Robert Bunsen invented the spectroscope and founded the science of spectroscopy, which we shall study in Chapter 42. They discovered the elements cesium and rubidium and invented astronomical spectroscopy.

Problem-Solving Strategy Kirchhoff's Rules

The following procedure is recommended for solving problems that involve circuits that cannot be reduced by the rules for combining resistors in series or parallel.

- 1. Conceptualize.** Study the circuit diagram and make sure you recognize all elements in the circuit. Identify the polarity of each battery and try to imagine the directions in which the current would exist in the batteries.
- 2. Categorize.** Determine whether the circuit can be reduced by means of combining series and parallel resistors. If so, use the techniques of Section 28.2. If not, apply Kirchhoff's rules according to the *Analyze* step below.
- 3. Analyze.** Assign labels to all known quantities and symbols to all unknown quantities. You must assign *directions* to the currents in each part of the circuit. Although the assignment of current directions is arbitrary, you must adhere *rigorously* to the directions you assign when you apply Kirchhoff's rules.

Apply the junction rule (Kirchhoff's first rule) to all junctions in the circuit except one. Now apply the loop rule (Kirchhoff's second rule) to as many loops in

► **Problem-Solving Strategy** *continued*

the circuit as are needed to obtain, in combination with the equations from the junction rule, as many equations as there are unknowns. To apply this rule, you must choose a direction in which to travel around the loop (either clockwise or counterclockwise) and correctly identify the change in potential as you cross each element. Be careful with signs!

Solve the equations simultaneously for the unknown quantities.

4. Finalize. Check your numerical answers for consistency. Do not be alarmed if any of the resulting currents have a negative value. That only means you have guessed the direction of that current incorrectly, but *its magnitude will be correct*.

Example 28.6 **A Single-Loop Circuit**

A single-loop circuit contains two resistors and two batteries as shown in Figure 28.14. (Neglect the internal resistances of the batteries.) Find the current in the circuit.

SOLUTION

Conceptualize Figure 28.14 shows the polarities of the batteries and a guess at the direction of the current. The 12-V battery is the stronger of the two, so the current should be counterclockwise. Therefore, we expect our guess for the direction of the current to be wrong, but we will continue and see how this incorrect guess is represented by our final answer.

Categorize We do not need Kirchhoff's rules to analyze this simple circuit, but let's use them anyway simply to see how they are applied. There are no junctions in this single-loop circuit; therefore, the current is the same in all elements.

Analyze Let's assume the current is clockwise as shown in Figure 28.14. Traversing the circuit in the clockwise direction, starting at a , we see that $a \rightarrow b$ represents a potential difference of $+\mathcal{E}_1$, $b \rightarrow c$ represents a potential difference of $-IR_1$, $c \rightarrow d$ represents a potential difference of $-\mathcal{E}_2$, and $d \rightarrow a$ represents a potential difference of $-IR_2$.

Apply Kirchhoff's loop rule to the single loop in the circuit:

$$\sum \Delta V = 0 \rightarrow \mathcal{E}_1 - IR_1 - \mathcal{E}_2 - IR_2 = 0$$

Solve for I and use the values given in Figure 28.14:

$$(1) \quad I = \frac{\mathcal{E}_1 - \mathcal{E}_2}{R_1 + R_2} = \frac{6.0 \text{ V} - 12 \text{ V}}{8.0 \Omega + 10 \Omega} = -0.33 \text{ A}$$

Finalize The negative sign for I indicates that the direction of the current is opposite the assumed direction. The emfs in the numerator subtract because the batteries in Figure 28.14 have opposite polarities. The resistances in the denominator add because the two resistors are in series.

WHAT IF? What if the polarity of the 12.0-V battery were reversed? How would that affect the circuit?

Answer Although we could repeat the Kirchhoff's rules calculation, let's instead examine Equation (1) and modify it accordingly. Because the polarities of the two batteries are now in the same direction, the signs of \mathcal{E}_1 and \mathcal{E}_2 are the same and Equation (1) becomes

$$I = \frac{\mathcal{E}_1 + \mathcal{E}_2}{R_1 + R_2} = \frac{6.0 \text{ V} + 12 \text{ V}}{8.0 \Omega + 10 \Omega} = 1.0 \text{ A}$$

Example 28.7 **A Multiloop Circuit**

Find the currents I_1 , I_2 , and I_3 in the circuit shown in Figure 28.15 on page 846.

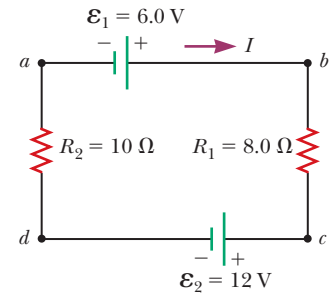

Figure 28.14 (Example 28.6) A series circuit containing two batteries and two resistors, where the polarities of the batteries are in opposition.

continued

28.7 continued

SOLUTION

Conceptualize Imagine physically rearranging the circuit while keeping it electrically the same. Can you rearrange it so that it consists of simple series or parallel combinations of resistors? You should find that you cannot. (If the 10.0-V battery were removed and replaced by a wire from b to the 6.0- Ω resistor, the circuit would consist of only series and parallel combinations.)

Categorize We cannot simplify the circuit by the rules associated with combining resistances in series and in parallel. Therefore, this problem is one in which we must use Kirchhoff's rules.

Analyze We arbitrarily choose the directions of the currents as labeled in Figure 28.15.

Apply Kirchhoff's junction rule to junction c :

$$(1) \quad I_1 + I_2 - I_3 = 0$$

We now have one equation with three unknowns: I_1 , I_2 , and I_3 . There are three loops in the circuit: $abcd$, $befcb$, and $aefta$. We need only two loop equations to determine the unknown currents. (The third equation would give no new information.) Let's choose to traverse these loops in the clockwise direction. Apply Kirchhoff's loop rule to loops $abcd$ and $befcb$:

$$abcd: (2) \quad 10.0 \text{ V} - (6.0 \Omega)I_1 - (2.0 \Omega)I_3 = 0$$

$$befcb: -(4.0 \Omega)I_2 - 14.0 \text{ V} + (6.0 \Omega)I_1 - 10.0 \text{ V} = 0$$

$$(3) \quad -24.0 \text{ V} + (6.0 \Omega)I_1 - (4.0 \Omega)I_2 = 0$$

Solve Equation (1) for I_3 and substitute into Equation (2):

$$10.0 \text{ V} - (6.0 \Omega)I_1 - (2.0 \Omega)(I_1 + I_2) = 0$$

$$(4) \quad 10.0 \text{ V} - (8.0 \Omega)I_1 - (2.0 \Omega)I_2 = 0$$

Multiply each term in Equation (3) by 4 and each term in Equation (4) by 3:

$$(5) \quad -96.0 \text{ V} + (24.0 \Omega)I_1 - (16.0 \Omega)I_2 = 0$$

$$(6) \quad 30.0 \text{ V} - (24.0 \Omega)I_1 - (6.0 \Omega)I_2 = 0$$

Add Equation (6) to Equation (5) to eliminate I_1 and find I_2 :

$$-66.0 \text{ V} - (22.0 \Omega)I_2 = 0$$

$$I_2 = -3.0 \text{ A}$$

Use this value of I_2 in Equation (3) to find I_1 :

$$-24.0 \text{ V} + (6.0 \Omega)I_1 - (4.0 \Omega)(-3.0 \text{ A}) = 0$$

$$-24.0 \text{ V} + (6.0 \Omega)I_1 + 12.0 \text{ V} = 0$$

$$I_1 = 2.0 \text{ A}$$

Use Equation (1) to find I_3 :

$$I_3 = I_1 + I_2 = 2.0 \text{ A} - 3.0 \text{ A} = -1.0 \text{ A}$$

Finalize Because our values for I_2 and I_3 are negative, the directions of these currents are opposite those indicated in Figure 28.15. The numerical values for the currents are correct. Despite the incorrect direction, we *must* continue to use these negative values in subsequent calculations because our equations were established with our original choice of direction. What would have happened had we left the current directions as labeled in Figure 28.15 but traversed the loops in the opposite direction?

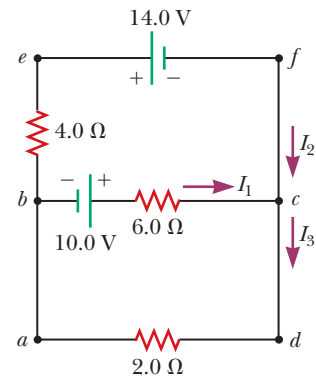

Figure 28.15 (Example 28.7) A circuit containing different branches.

28.4 RC Circuits

So far, we have analyzed direct-current circuits in which the current is constant. In DC circuits containing capacitors, the current is always in the same direction but may vary in magnitude at different times. A circuit containing a series combination of a resistor and a capacitor is called an **RC circuit**.

Charging a Capacitor

Figure 28.16 shows a simple series RC circuit. Let's assume the capacitor in this circuit is initially uncharged. There is no current while the switch is open (Fig. 28.16a). If the switch is thrown to position a at $t = 0$ (Fig. 28.16b), however, charge begins to flow, setting up a current in the circuit, and the capacitor begins to charge.³ Notice that during charging, charges do not jump across the capacitor plates because the gap between the plates represents an open circuit. Instead, charge is transferred between each plate and its connecting wires due to the electric field established in the wires by the battery until the capacitor is fully charged. As the plates are being charged, the potential difference across the capacitor increases. The value of the maximum charge on the plates depends on the voltage of the battery. Once the maximum charge is reached, the current in the circuit is zero because the potential difference across the capacitor matches that supplied by the battery.

To analyze this circuit quantitatively, let's apply Kirchhoff's loop rule to the circuit after the switch is thrown to position a . Traversing the loop in Figure 28.16b clockwise gives

$$\mathcal{E} - \frac{q}{C} - iR = 0 \quad (28.11)$$

where q/C is the potential difference across the capacitor and iR is the potential difference across the resistor. We have used the sign conventions discussed earlier for the signs on \mathcal{E} and iR . The capacitor is traversed in the direction from the positive plate to the negative plate, which represents a decrease in potential. Therefore, we use a negative sign for this potential difference in Equation 28.11. Note that lowercase q and i are *instantaneous* values that depend on time (as opposed to steady-state values) as the capacitor is being charged.

We can use Equation 28.11 to find the initial current I_i in the circuit and the maximum charge Q_{\max} on the capacitor. At the instant the switch is thrown to position a ($t = 0$), the charge on the capacitor is zero. Equation 28.11 shows that the initial current I_i in the circuit is a maximum and is given by

$$I_i = \frac{\mathcal{E}}{R} \quad (\text{current at } t = 0) \quad (28.12)$$

At this time, the potential difference from the battery terminals appears entirely across the resistor. Later, when the capacitor is charged to its maximum value Q_{\max} , charges cease to flow, the current in the circuit is zero, and the potential difference from the battery terminals appears entirely across the capacitor. Substituting $i = 0$ into Equation 28.11 gives the maximum charge on the capacitor:

$$Q_{\max} = C\mathcal{E} \quad (\text{maximum charge}) \quad (28.13)$$

To determine analytical expressions for the time dependence of the charge and current, we must solve Equation 28.11, a single equation containing two variables q and i . The current in all parts of the series circuit must be the same. Therefore, the current in the resistance R must be the same as the current between each capacitor plate and the wire connected to it. This current is equal to the time rate of change of the charge on the capacitor plates. Therefore, we substitute $i = dq/dt$ into Equation 28.11 and rearrange the equation:

$$\frac{dq}{dt} = \frac{\mathcal{E}}{R} - \frac{q}{RC}$$

To find an expression for q , we solve this separable differential equation as follows. First combine the terms on the right-hand side:

$$\frac{dq}{dt} = \frac{C\mathcal{E}}{RC} - \frac{q}{RC} = -\frac{q - C\mathcal{E}}{RC}$$

³In previous discussions of capacitors, we assumed a steady-state situation, in which no current was present in any branch of the circuit containing a capacitor. Now we are considering the case *before* the steady-state condition is realized; in this situation, charges are moving and a current exists in the wires connected to the capacitor.

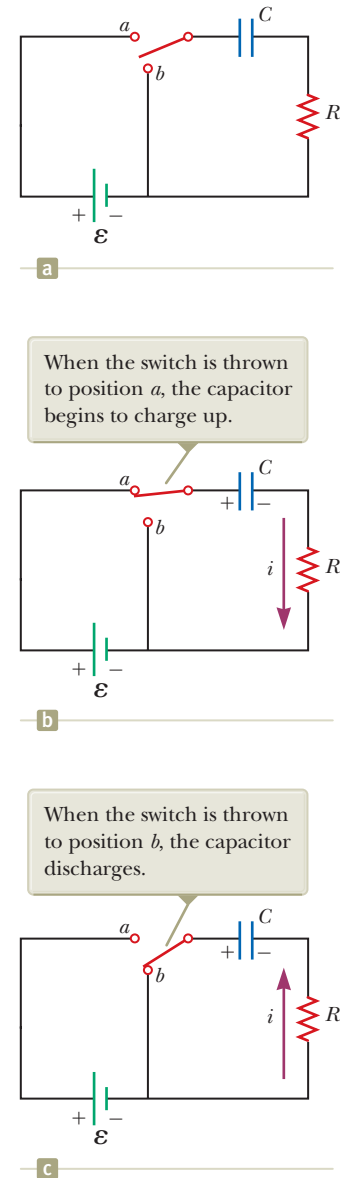

Figure 28.16 A capacitor in series with a resistor, switch, and battery.

Multiply this equation by dt and divide by $q - C\mathcal{E}$:

$$\frac{dq}{q - C\mathcal{E}} = -\frac{1}{RC} dt$$

Integrate this expression, using $q = 0$ at $t = 0$:

$$\int_0^q \frac{dq}{q - C\mathcal{E}} = -\frac{1}{RC} \int_0^t dt$$

$$\ln\left(\frac{q - C\mathcal{E}}{-C\mathcal{E}}\right) = -\frac{t}{RC}$$

From the definition of the natural logarithm, we can write this expression as

$$q(t) = C\mathcal{E}(1 - e^{-t/RC}) = Q_{\max}(1 - e^{-t/RC}) \quad (28.14)$$

where e is the base of the natural logarithm and we have made the substitution from Equation 28.13.

We can find an expression for the charging current by differentiating Equation 28.14 with respect to time. Using $i = dq/dt$, we find that

$$i(t) = \frac{\mathcal{E}}{R} e^{-t/RC} \quad (28.15)$$

Plots of capacitor charge and circuit current versus time are shown in Figure 28.17. Notice that the charge is zero at $t = 0$ and approaches the maximum value $C\mathcal{E}$ as $t \rightarrow \infty$. The current has its maximum value $I_i = \mathcal{E}/R$ at $t = 0$ and decays exponentially to zero as $t \rightarrow \infty$. The quantity RC , which appears in the exponents of Equations 28.14 and 28.15, is called the **time constant** τ of the circuit:

$$\tau = RC \quad (28.16)$$

The time constant represents the time interval during which the current decreases to $1/e$ of its initial value; that is, after a time interval τ , the current decreases to $i = e^{-1}I_i = 0.368I_i$. After a time interval 2τ , the current decreases to $i = e^{-2}I_i = 0.135I_i$, and so forth. Likewise, in a time interval τ , the charge increases from zero to $C\mathcal{E}[1 - e^{-1}] = 0.632C\mathcal{E}$.

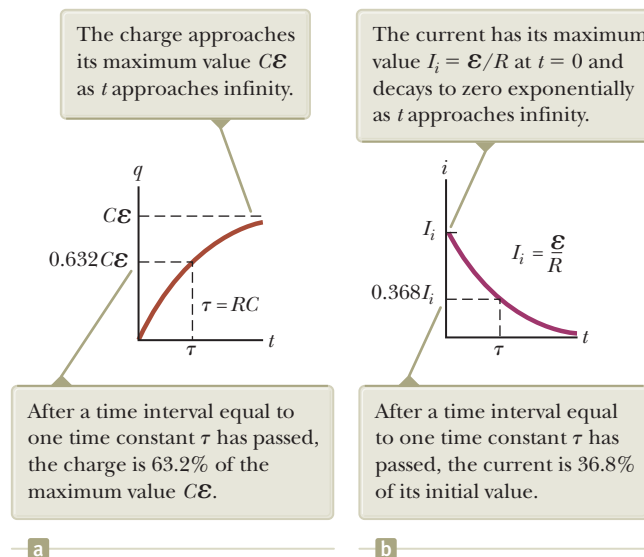

Figure 28.17 (a) Plot of capacitor charge versus time for the circuit shown in Figure 28.16b. (b) Plot of current versus time for the circuit shown in Figure 28.16b.

Charge as a function of time
for a capacitor being
charged

Current as a function of time
for a capacitor being
charged

The following dimensional analysis shows that τ has units of time:

$$[\tau] = [RC] = \left[\left(\frac{\Delta V}{I} \right) \left(\frac{Q}{\Delta V} \right) \right] = \left[\frac{Q}{Q/\Delta t} \right] = [\Delta t] = \text{T}$$

Because $\tau = RC$ has units of time, the combination t/RC is dimensionless, as it must be to be an exponent of e in Equations 28.14 and 28.15.

The energy supplied by the battery during the time interval required to fully charge the capacitor is $Q_{\max}\mathcal{E} = C\mathcal{E}^2$. After the capacitor is fully charged, the energy stored in the capacitor is $\frac{1}{2}Q_{\max}\mathcal{E} = \frac{1}{2}C\mathcal{E}^2$, which is only half the energy output of the battery. It is left as a problem (Problem 68) to show that the remaining half of the energy supplied by the battery appears as internal energy in the resistor.

Discharging a Capacitor

Imagine that the capacitor in Figure 28.16b is completely charged. An initial potential difference Q_i/C exists across the capacitor, and there is zero potential difference across the resistor because $i = 0$. If the switch is now thrown to position b at $t = 0$ (Fig. 28.16c), the capacitor begins to discharge through the resistor. At some time t during the discharge, the current in the circuit is i and the charge on the capacitor is q . The circuit in Figure 28.16c is the same as the circuit in Figure 28.16b except for the absence of the battery. Therefore, we eliminate the emf \mathcal{E} from Equation 28.11 to obtain the appropriate loop equation for the circuit in Figure 28.16c:

$$-\frac{q}{C} - iR = 0 \quad (28.17)$$

When we substitute $i = dq/dt$ into this expression, it becomes

$$\begin{aligned} -R \frac{dq}{dt} &= \frac{q}{C} \\ \frac{dq}{q} &= -\frac{1}{RC} dt \end{aligned}$$

Integrating this expression using $q = Q_i$ at $t = 0$ gives

$$\begin{aligned} \int_{Q_i}^q \frac{dq}{q} &= -\frac{1}{RC} \int_0^t dt \\ \ln \left(\frac{q}{Q_i} \right) &= -\frac{t}{RC} \end{aligned}$$

$$q(t) = Q_i e^{-t/RC} \quad (28.18)$$

Differentiating Equation 28.18 with respect to time gives the instantaneous current as a function of time:

$$i(t) = -\frac{Q_i}{RC} e^{-t/RC} \quad (28.19)$$

where $Q_i/RC = I_i$ is the initial current. The negative sign indicates that as the capacitor discharges, the current direction is opposite its direction when the capacitor was being charged. (Compare the current directions in Figs. 28.16b and 28.16c.) Both the charge on the capacitor and the current decay exponentially at a rate characterized by the time constant $\tau = RC$.

- Quick Quiz 28.5** Consider the circuit in Figure 28.18 and assume the battery has no internal resistance. (i) Just after the switch is closed, what is the current in the battery? (a) 0 (b) $\mathcal{E}/2R$ (c) $2\mathcal{E}/R$ (d) \mathcal{E}/R (e) impossible to determine (ii) After a very long time, what is the current in the battery? Choose from the same choices.

◀ Charge as a function of time for a discharging capacitor

◀ Current as a function of time for a discharging capacitor

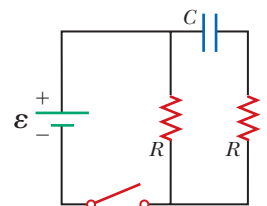

Figure 28.18 (Quick Quiz 28.5) How does the current vary after the switch is closed?

Conceptual Example 28.8 Intermittent Windshield Wipers

Many automobiles are equipped with windshield wipers that can operate intermittently during a light rainfall. How does the operation of such wipers depend on the charging and discharging of a capacitor?

SOLUTION

The wipers are part of an RC circuit whose time constant can be varied by selecting different values of R through a multiposition switch. As the voltage across the capacitor increases, the capacitor reaches a point at which it discharges and triggers the wipers. The circuit then begins another charging cycle. The time interval between the individual sweeps of the wipers is determined by the value of the time constant.

Example 28.9 Charging a Capacitor in an RC Circuit

An uncharged capacitor and a resistor are connected in series to a battery as shown in Figure 28.16, where $\mathcal{E} = 12.0$ V, $C = 5.00$ μF , and $R = 8.00 \times 10^5$ Ω . The switch is thrown to position a . Find the time constant of the circuit, the maximum charge on the capacitor, the maximum current in the circuit, and the charge and current as functions of time.

SOLUTION

Conceptualize Study Figure 28.16 and imagine throwing the switch to position a as shown in Figure 28.16b. Upon doing so, the capacitor begins to charge.

Categorize We evaluate our results using equations developed in this section, so we categorize this example as a substitution problem.

Evaluate the time constant of the circuit from Equation 28.16:

$$\tau = RC = (8.00 \times 10^5 \Omega)(5.00 \times 10^{-6} \text{ F}) = 4.00 \text{ s}$$

Evaluate the maximum charge on the capacitor from Equation 28.13:

$$Q_{\text{max}} = C\mathcal{E} = (5.00 \mu\text{F})(12.0 \text{ V}) = 60.0 \mu\text{C}$$

Evaluate the maximum current in the circuit from Equation 28.12:

$$I_i = \frac{\mathcal{E}}{R} = \frac{12.0 \text{ V}}{8.00 \times 10^5 \Omega} = 15.0 \mu\text{A}$$

Use these values in Equations 28.14 and 28.15 to find the charge and current as functions of time:

$$(1) \quad q(t) = 60.0(1 - e^{-t/4.00})$$

$$(2) \quad i(t) = 15.0e^{-t/4.00}$$

In Equations (1) and (2), q is in microcoulombs, i is in microamperes, and t is in seconds.

Example 28.10 Discharging a Capacitor in an RC Circuit

Consider a capacitor of capacitance C that is being discharged through a resistor of resistance R as shown in Figure 28.16c.

(A) After how many time constants is the charge on the capacitor one-fourth its initial value?

SOLUTION

Conceptualize Study Figure 28.16 and imagine throwing the switch to position b as shown in Figure 28.16c. Upon doing so, the capacitor begins to discharge.

Categorize We categorize the example as one involving a discharging capacitor and use the appropriate equations.

28.10 continued

Analyze Substitute $q(t) = Q_i/4$ into Equation 28.18:

$$\frac{Q_i}{4} = Q_i e^{-t/RC}$$

$$\frac{1}{4} = e^{-t/RC}$$

Take the logarithm of both sides of the equation and solve for t :

$$-\ln 4 = -\frac{t}{RC}$$

$$t = RC \ln 4 = 1.39RC = 1.39\tau$$

(B) The energy stored in the capacitor decreases with time as the capacitor discharges. After how many time constants is this stored energy one-fourth its initial value?

SOLUTION

Use Equations 26.11 and 28.18 to express the energy stored in the capacitor at any time t :

$$(1) \quad U(t) = \frac{q^2}{2C} = \frac{Q_i^2}{2C} e^{-2t/RC}$$

Substitute $U(t) = \frac{1}{4}(Q_i^2/2C)$ into Equation (1):

$$\frac{1}{4} \frac{Q_i^2}{2C} = \frac{Q_i^2}{2C} e^{-2t/RC}$$

$$\frac{1}{4} = e^{-2t/RC}$$

Take the logarithm of both sides of the equation and solve for t :

$$-\ln 4 = -\frac{2t}{RC}$$

$$t = \frac{1}{2}RC \ln 4 = 0.693RC = 0.693\tau$$

Finalize Notice that because the energy depends on the square of the charge, the energy in the capacitor drops more rapidly than the charge on the capacitor.

WHAT IF? What if you want to describe the circuit in terms of the time interval required for the charge to fall to one-half its original value rather than by the time constant τ ? That would give a parameter for the circuit called its *half-life* $t_{1/2}$. How is the half-life related to the time constant?

Answer In one half-life, the charge falls from Q_i to $Q_i/2$. Therefore, from Equation 28.18,

$$\frac{Q_i}{2} = Q_i e^{-t_{1/2}/RC} \rightarrow \frac{1}{2} = e^{-t_{1/2}/RC}$$

which leads to

$$t_{1/2} = 0.693\tau$$

The concept of half-life will be important to us when we study nuclear decay in Chapter 44. The radioactive decay of an unstable sample behaves in a mathematically similar manner to a discharging capacitor in an RC circuit.

Example 28.11 Energy Delivered to a Resistor **AM**

A $5.00\text{-}\mu\text{F}$ capacitor is charged to a potential difference of 800 V and then discharged through a resistor. How much energy is delivered to the resistor in the time interval required to fully discharge the capacitor?

SOLUTION

Conceptualize In Example 28.10, we considered the energy decrease in a discharging capacitor to a value of one-fourth the initial energy. In this example, the capacitor fully discharges.

Categorize We solve this example using two approaches. The first approach is to model the circuit as an *isolated system* for *energy*. Because energy in an isolated system is conserved, the initial electric potential energy U_E stored in the

continued

28.11 continued

capacitor is transformed into internal energy $E_{\text{int}} = E_R$ in the resistor. The second approach is to model the resistor as a *nonisolated system for energy*. Energy enters the resistor by electrical transmission from the capacitor, causing an increase in the resistor's internal energy.

Analyze We begin with the isolated system approach.

Write the appropriate reduction of the conservation of energy equation, Equation 8.2:

$$\Delta U + \Delta E_{\text{int}} = 0$$

Substitute the initial and final values of the energies:

$$(0 - U_E) + (E_{\text{int}} - 0) = 0 \rightarrow E_R = U_E$$

Use Equation 26.11 for the electric potential energy in the capacitor:

$$E_R = \frac{1}{2}C\mathcal{E}^2$$

Substitute numerical values:

$$E_R = \frac{1}{2}(5.00 \times 10^{-6} \text{ F})(800 \text{ V})^2 = \mathbf{1.60 \text{ J}}$$

The second approach, which is more difficult but perhaps more instructive, is to note that as the capacitor discharges through the resistor, the rate at which energy is delivered to the resistor by electrical transmission is i^2R , where i is the instantaneous current given by Equation 28.19.

Evaluate the energy delivered to the resistor by integrating the power over all time because it takes an infinite time interval for the capacitor to completely discharge:

$$P = \frac{dE}{dt} \rightarrow E_R = \int_0^{\infty} P dt$$

Substitute for the power delivered to the resistor:

$$E_R = \int_0^{\infty} i^2 R dt$$

Substitute for the current from Equation 28.19:

$$E_R = \int_0^{\infty} \left(-\frac{Q_i}{RC} e^{-t/RC} \right)^2 R dt = \frac{Q_i^2}{RC^2} \int_0^{\infty} e^{-2t/RC} dt = \frac{\mathcal{E}^2}{R} \int_0^{\infty} e^{-2t/RC} dt$$

Substitute the value of the integral, which is $RC/2$ (see Problem 44):

$$E_R = \frac{\mathcal{E}^2}{R} \left(\frac{RC}{2} \right) = \frac{1}{2}C\mathcal{E}^2$$

Finalize This result agrees with that obtained using the isolated system approach, as it must. We can use this second approach to find the total energy delivered to the resistor at *any* time after the switch is closed by simply replacing the upper limit in the integral with that specific value of t .

28.5 Household Wiring and Electrical Safety

Many considerations are important in the design of an electrical system of a home that will provide adequate electrical service for the occupants while maximizing their safety. We discuss some aspects of a home electrical system in this section.

Household Wiring

Household circuits represent a practical application of some of the ideas presented in this chapter. In our world of electrical appliances, it is useful to understand the power requirements and limitations of conventional electrical systems and the safety measures that prevent accidents.

In a conventional installation, the utility company distributes electric power to individual homes by means of a pair of wires, with each home connected in paral-

labeled to these wires. One wire is called the *live wire*⁴ as illustrated in Figure 28.19, and the other is called the *neutral wire*. The neutral wire is grounded; that is, its electric potential is taken to be zero. The potential difference between the live and neutral wires is approximately 120 V. This voltage alternates in time, and the potential of the live wire oscillates relative to ground. Much of what we have learned so far for the constant-emf situation (direct current) can also be applied to the alternating current that power companies supply to businesses and households. (Alternating voltage and current are discussed in Chapter 33.)

To record a household's energy consumption, a meter is connected in series with the live wire entering the house. After the meter, the wire splits so that there are several separate circuits in parallel distributed throughout the house. Each circuit contains a circuit breaker (or, in older installations, a fuse). A circuit breaker is a special switch that opens if the current exceeds the rated value for the circuit breaker. The wire and circuit breaker for each circuit are carefully selected to meet the current requirements for that circuit. If a circuit is to carry currents as large as 30 A, a heavy wire and an appropriate circuit breaker must be selected to handle this current. A circuit used to power only lamps and small appliances often requires only 20 A. Each circuit has its own circuit breaker to provide protection for that part of the entire electrical system of the house.

As an example, consider a circuit in which a toaster oven, a microwave oven, and a coffee maker are connected (corresponding to R_1 , R_2 , and R_3 in Fig. 28.19). We can calculate the current in each appliance by using the expression $P = I \Delta V$. The toaster oven, rated at 1 000 W, draws a current of $1\,000\text{ W}/120\text{ V} = 8.33\text{ A}$. The microwave oven, rated at 1 300 W, draws 10.8 A, and the coffee maker, rated at 800 W, draws 6.67 A. When the three appliances are operated simultaneously, they draw a total current of 25.8 A. Therefore, the circuit must be wired to handle at least this much current. If the rating of the circuit breaker protecting the circuit is too small—say, 20 A—the breaker will be tripped when the third appliance is turned on, preventing all three appliances from operating. To avoid this situation, the toaster oven and coffee maker can be operated on one 20-A circuit and the microwave oven on a separate 20-A circuit.

Many heavy-duty appliances such as electric ranges and clothes dryers require 240 V for their operation. The power company supplies this voltage by providing a third wire that is 120 V below ground potential (Fig. 28.20). The potential difference between this live wire and the other live wire (which is 120 V above ground potential) is 240 V. An appliance that operates from a 240-V line requires half as much current compared with operating it at 120 V; therefore, smaller wires can be used in the higher-voltage circuit without overheating.

Electrical Safety

When the live wire of an electrical outlet is connected directly to ground, the circuit is completed and a *short-circuit condition* exists. A short circuit occurs when almost zero resistance exists between two points at different potentials, and the result is a very large current. When that happens accidentally, a properly operating circuit breaker opens the circuit and no damage is done. A person in contact with ground, however, can be electrocuted by touching the live wire of a frayed cord or other exposed conductor. An exceptionally effective (and dangerous!) ground contact is made when the person either touches a water pipe (normally at ground potential) or stands on the ground with wet feet. The latter situation represents effective ground contact because normal, nondistilled water is a conductor due to the large number of ions associated with impurities. This situation should be avoided at all cost.

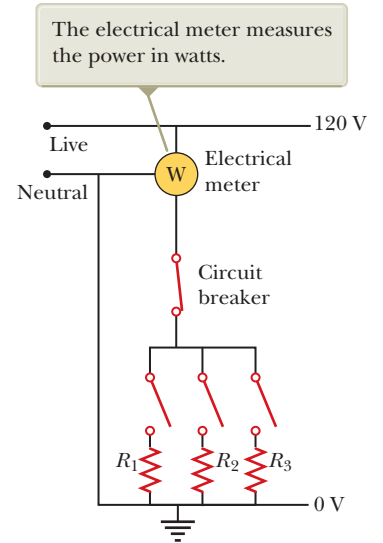

Figure 28.19 Wiring diagram for a household circuit. The resistances represent appliances or other electrical devices that operate with an applied voltage of 120 V.

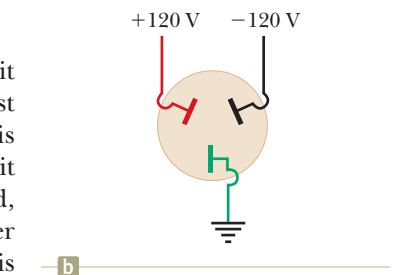
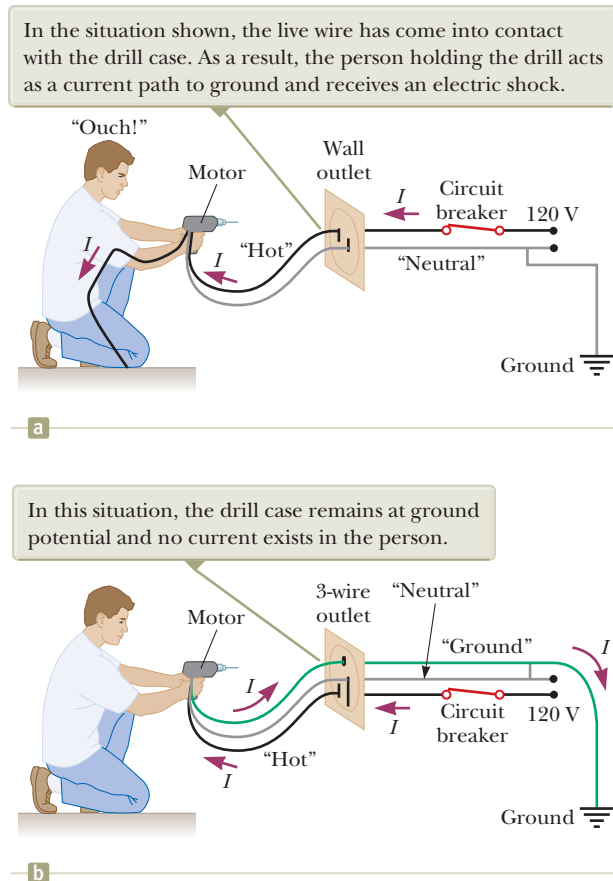

Figure 28.20 (a) An outlet for connection to a 240-V supply. (b) The connections for each of the openings in a 240-V outlet.

⁴*Live wire* is a common expression for a conductor whose electric potential is above or below ground potential.

Figure 28.21 (a) A diagram of the circuit for an electric drill with only two connecting wires. The normal current path is from the live wire through the motor connections and back to ground through the neutral wire. (b) This shock can be avoided by connecting the drill case to ground through a third ground wire. The wire colors represent electrical standards in the United States: the “hot” wire is black, the ground wire is green, and the neutral wire is white (shown as gray in the figure).



Electric shock can result in fatal burns or can cause the muscles of vital organs such as the heart to malfunction. The degree of damage to the body depends on the magnitude of the current, the length of time it acts, the part of the body touched by the live wire, and the part of the body in which the current exists. Currents of 5 mA or less cause a sensation of shock, but ordinarily do little or no damage. If the current is larger than about 10 mA, the muscles contract and the person may be unable to release the live wire. If the body carries a current of about 100 mA for only a few seconds, the result can be fatal. Such a large current paralyzes the respiratory muscles and prevents breathing. In some cases, currents of approximately 1 A can produce serious (and sometimes fatal) burns. In practice, no contact with live wires is regarded as safe whenever the voltage is greater than 24 V.

Many 120-V outlets are designed to accept a three-pronged power cord. (This feature is required in all new electrical installations.) One of these prongs is the live wire at a nominal potential of 120 V. The second is the neutral wire, nominally at 0 V, which carries current to ground. Figure 28.21a shows a connection to an electric drill with only these two wires. If the live wire accidentally makes contact with the casing of the electric drill (which can occur if the wire insulation wears off), current can be carried to ground by way of the person, resulting in an electric shock. The third wire in a three-pronged power cord, the round prong, is a safety ground wire that normally carries no current. It is both grounded and connected directly to the casing of the appliance. If the live wire is accidentally shorted to the casing in this situation, most of the current takes the low-resistance path through the appliance to ground as shown in Figure 28.21b.

Special power outlets called *ground-fault circuit interrupters*, or GFCIs, are used in kitchens, bathrooms, basements, exterior outlets, and other hazardous areas of homes. These devices are designed to protect persons from electric shock by sensing small currents (< 5 mA) leaking to ground. (The principle of their operation

is described in Chapter 31.) When an excessive leakage current is detected, the current is shut off in less than 1 ms.

Summary

Definition

The **emf** of a battery is equal to the voltage across its terminals when the current is zero. That is, the emf is equivalent to the **open-circuit voltage** of the battery.

Concepts and Principles

The **equivalent resistance** of a set of resistors connected in a **series combination** is

$$R_{\text{eq}} = R_1 + R_2 + R_3 + \cdots \quad (28.6)$$

The **equivalent resistance** of a set of resistors connected in a **parallel combination** is found from the relationship

$$\frac{1}{R_{\text{eq}}} = \frac{1}{R_1} + \frac{1}{R_2} + \frac{1}{R_3} + \cdots \quad (28.8)$$

Circuits involving more than one loop are conveniently analyzed with the use of **Kirchhoff's rules**:

1. Junction rule. At any junction, the sum of the currents must equal zero:

$$\sum_{\text{junction}} I = 0 \quad (28.9)$$

2. Loop rule. The sum of the potential differences across all elements around any circuit loop must be zero:

$$\sum_{\text{closed loop}} \Delta V = 0 \quad (28.10)$$

When a resistor is traversed in the direction of the current, the potential difference ΔV across the resistor is $-IR$. When a resistor is traversed in the direction opposite the current, $\Delta V = +IR$. When a source of emf is traversed in the direction of the emf (negative terminal to positive terminal), the potential difference is $+\mathcal{E}$. When a source of emf is traversed opposite the emf (positive to negative), the potential difference is $-\mathcal{E}$.

If a capacitor is charged with a battery through a resistor of resistance R , the charge on the capacitor and the current in the circuit vary in time according to the expressions

$$q(t) = Q_{\text{max}}(1 - e^{-t/RC}) \quad (28.14)$$

$$i(t) = \frac{\mathcal{E}}{R} e^{-t/RC} \quad (28.15)$$

where $Q_{\text{max}} = C\mathcal{E}$ is the maximum charge on the capacitor. The product RC is called the **time constant** τ of the circuit.

If a charged capacitor of capacitance C is discharged through a resistor of resistance R , the charge and current decrease exponentially in time according to the expressions

$$q(t) = Q_i e^{-t/RC} \quad (28.18)$$

$$i(t) = -\frac{Q_i}{RC} e^{-t/RC} \quad (28.19)$$

where Q_i is the initial charge on the capacitor and Q_i/RC is the initial current in the circuit.

Objective Questions

1. denotes answer available in *Student Solutions Manual/Study Guide*

- Is a circuit breaker wired (a) in series with the device it is protecting, (b) in parallel, or (c) neither in series or in parallel, or (d) is it impossible to tell?
- A battery has some internal resistance. **(i)** Can the potential difference across the terminals of the battery be equal to its emf? (a) no (b) yes, if the battery

is absorbing energy by electrical transmission (c) yes, if more than one wire is connected to each terminal (d) yes, if the current in the battery is zero (e) yes, with no special condition required. **(ii)** Can the terminal voltage exceed the emf? Choose your answer from the same possibilities as in part (i).

3. The terminals of a battery are connected across two resistors in series. The resistances of the resistors are not the same. Which of the following statements are correct? Choose all that are correct. (a) The resistor with the smaller resistance carries more current than the other resistor. (b) The resistor with the larger resistance carries less current than the other resistor. (c) The current in each resistor is the same. (d) The potential difference across each resistor is the same. (e) The potential difference is greatest across the resistor closest to the positive terminal.
4. When operating on a 120-V circuit, an electric heater receives 1.30×10^3 W of power, a toaster receives 1.00×10^3 W, and an electric oven receives 1.54×10^3 W. If all three appliances are connected in parallel on a 120-V circuit and turned on, what is the total current drawn from an external source? (a) 24.0 A (b) 32.0 A (c) 40.0 A (d) 48.0 A (e) none of those answers
5. If the terminals of a battery with zero internal resistance are connected across two identical resistors in series, the total power delivered by the battery is 8.00 W. If the same battery is connected across the same resistors in parallel, what is the total power delivered by the battery? (a) 16.0 W (b) 32.0 W (c) 2.00 W (d) 4.00 W (e) none of those answers
6. Several resistors are connected in series. Which of the following statements is correct? Choose all that are correct. (a) The equivalent resistance is greater than any of the resistances in the group. (b) The equivalent resistance is less than any of the resistances in the group. (c) The equivalent resistance depends on the voltage applied across the group. (d) The equivalent resistance is equal to the sum of the resistances in the group. (e) None of those statements is correct.
7. What is the time constant of the circuit shown in Figure OQ28.7? Each of the five resistors has resistance R , and each of the five capacitors has capacitance C . The internal resistance of the battery is negligible. (a) RC (b) $5RC$ (c) $10RC$ (d) $25RC$ (e) none of those answers

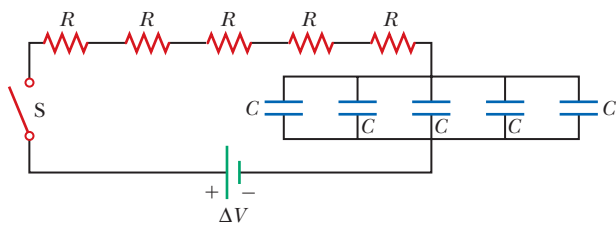

Figure OQ28.7

8. When resistors with different resistances are connected in series, which of the following must be the same for each resistor? Choose all correct answers. (a) potential difference (b) current (c) power delivered (d) charge entering each resistor in a given time interval (e) none of those answers
9. When resistors with different resistances are connected in parallel, which of the following must be the same for each resistor? Choose all correct answers. (a) potential

difference (b) current (c) power delivered (d) charge entering each resistor in a given time interval (e) none of those answers

10. The terminals of a battery are connected across two resistors in parallel. The resistances of the resistors are not the same. Which of the following statements is correct? Choose all that are correct. (a) The resistor with the larger resistance carries more current than the other resistor. (b) The resistor with the larger resistance carries less current than the other resistor. (c) The potential difference across each resistor is the same. (d) The potential difference across the larger resistor is greater than the potential difference across the smaller resistor. (e) The potential difference is greater across the resistor closer to the battery.
11. Are the two headlights of a car wired (a) in series with each other, (b) in parallel, or (c) neither in series nor in parallel, or (d) is it impossible to tell?
12. In the circuit shown in Figure OQ28.12, each battery is delivering energy to the circuit by electrical transmission. All the resistors have equal resistance. (i) Rank the electric potentials at points a , b , c , d , and e from highest to lowest, noting any cases of equality in the ranking. (ii) Rank the magnitudes of the currents at the same points from greatest to least, noting any cases of equality.

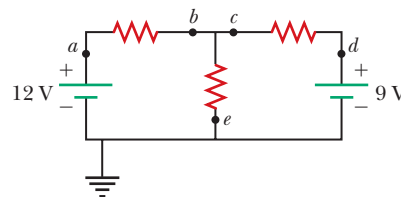

Figure OQ28.12

13. Several resistors are connected in parallel. Which of the following statements are correct? Choose all that are correct. (a) The equivalent resistance is greater than any of the resistances in the group. (b) The equivalent resistance is less than any of the resistances in the group. (c) The equivalent resistance depends on the voltage applied across the group. (d) The equivalent resistance is equal to the sum of the resistances in the group. (e) None of those statements is correct.
14. A circuit consists of three identical lamps connected to a battery as in Figure OQ28.14. The battery has some internal resistance. The switch S , originally open, is closed. (i) What then happens to the brightness of lamp B? (a) It increases. (b) It decreases somewhat. (c) It does not change. (d) It drops to zero. For parts (ii) to (vi), choose from the same possibilities (a) through (d). (ii) What happens to the brightness of lamp C? (iii) What happens to the current in the battery? (iv) What happens to the potential difference across lamp A? (v) What happens to the potential difference

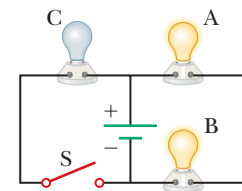

Figure OQ28.14

across lamp C? (vi) What happens to the total power delivered to the lamps by the battery?

15. A series circuit consists of three identical lamps connected to a battery as shown in Figure OQ28.15. The switch S , originally open, is closed. (i) What then happens to the brightness of lamp B? (a) It increases. (b) It decreases somewhat. (c) It does not change. (d) It drops to zero. For parts (ii) to (vi), choose from the same possibilities (a) through (d). (ii) What happens to the brightness of lamp C? (iii) What happens to the current in the battery? (iv) What happens to the potential difference across

lamp A? (v) What happens to the potential difference across lamp C? (vi) What happens to the total power delivered to the lamps by the battery?

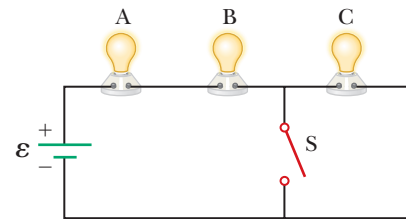

Figure OQ28.15

Conceptual Questions

1. denotes answer available in *Student Solutions Manual/Study Guide*

- Suppose a parachutist lands on a high-voltage wire and grabs the wire as she prepares to be rescued. (a) Will she be electrocuted? (b) If the wire then breaks, should she continue to hold onto the wire as she falls to the ground? Explain.
- A student claims that the second of two lightbulbs in series is less bright than the first because the first lightbulb uses up some of the current. How would you respond to this statement?
- Why is it possible for a bird to sit on a high-voltage wire without being electrocuted?
- Given three lightbulbs and a battery, sketch as many different electric circuits as you can.
- A ski resort consists of a few chairlifts and several interconnected downhill runs on the side of a mountain, with a lodge at the bottom. The chairlifts are analogous to batteries, and the runs are analogous to resistors. Describe how two runs can be in series. Describe how three runs can be in parallel. Sketch a junction between one chairlift and two runs. State Kirchhoff's junction rule for ski resorts. One of the skiers happens to be carrying a skydiver's altimeter. She never takes the same set of chairlifts and runs twice, but keeps passing you at the fixed location where you are working. State Kirchhoff's loop rule for ski resorts.

- Referring to Figure CQ28.6, describe what happens to the lightbulb after the switch is closed. Assume the capacitor has a large capacitance and is initially uncharged. Also assume the light illuminates when connected directly across the battery terminals.

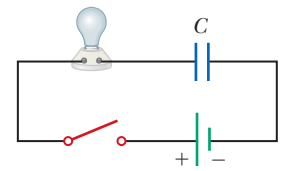

Figure CQ28.6

- So that your grandmother can listen to *A Prairie Home Companion*, you take her bedside radio to the hospital where she is staying. You are required to have a maintenance worker test the radio for electrical safety. Finding that it develops 120 V on one of its knobs, he does not let you take it to your grandmother's room. Your grandmother complains that she has had the radio for many years and nobody has ever gotten a shock from it. You end up having to buy a new plastic radio. (a) Why is your grandmother's old radio dangerous in a hospital room? (b) Will the old radio be safe back in her bedroom?
- (a) What advantage does 120-V operation offer over 240 V? (b) What disadvantages does it have?
- Is the direction of current in a battery always from the negative terminal to the positive terminal? Explain.
- Compare series and parallel resistors to the series and parallel rods in Figure 20.13 on page 610. How are the situations similar?

Problems

ENHANCED WebAssign The problems found in this chapter may be assigned online in Enhanced WebAssign

1. straightforward; 2. intermediate;
3. challenging

1. full solution available in the *Student Solutions Manual/Study Guide*

AMT Analysis Model tutorial available in Enhanced WebAssign

GP Guided Problem

M Master It tutorial available in Enhanced WebAssign

W Watch It video solution available in Enhanced WebAssign

Section 28.1 Electromotive Force

- A battery has an emf of 15.0 V. The terminal voltage of the battery is 11.6 V when it is delivering 20.0 W of

power to an external load resistor R . (a) What is the value of R ? (b) What is the internal resistance of the battery?

- 2.** Two 1.50-V batteries—with their positive terminals in the same direction—are inserted in series into a flashlight. One battery has an internal resistance of $0.255\ \Omega$, and the other has an internal resistance of $0.153\ \Omega$. When the switch is closed, the bulb carries a current of 600 mA. (a) What is the bulb's resistance? (b) What fraction of the chemical energy transformed appears as internal energy in the batteries?
- 3.** An automobile battery has an emf of 12.6 V and an internal resistance of $0.080\ \Omega$. The headlights together have an equivalent resistance of $5.00\ \Omega$ (assumed constant). What is the potential difference across the headlight bulbs (a) when they are the only load on the battery and (b) when the starter motor is operated, with 35.0 A of current in the motor?
- 4.** As in Example 28.2, consider a power supply with fixed emf \mathcal{E} and internal resistance r causing current in a load resistance R . In this problem, R is fixed and r is a variable. The efficiency is defined as the energy delivered to the load divided by the energy delivered by the emf. (a) When the internal resistance is adjusted for maximum power transfer, what is the efficiency? (b) What should be the internal resistance for maximum possible efficiency? (c) When the electric company sells energy to a customer, does it have a goal of high efficiency or of maximum power transfer? Explain. (d) When a student connects a loudspeaker to an amplifier, does she most want high efficiency or high power transfer? Explain.

Section 28.2 Resistors in Series and Parallel

- 5.** Three $100\text{-}\Omega$ resistors are connected as shown in Figure P28.5. The maximum power that can safely be delivered to any one resistor is 25.0 W. (a) What is the maximum potential difference that can be applied to the terminals a and b ? (b) For the voltage determined in part (a), what is the power delivered to each resistor? (c) What is the total power delivered to the combination of resistors?

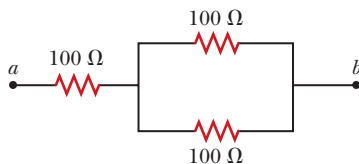

Figure P28.5

- 6.** A lightbulb marked “75 W [at] 120 V” is screwed into a socket at one end of a long extension cord, in which each of the two conductors has resistance $0.800\ \Omega$. The other end of the extension cord is plugged into a 120-V outlet. (a) Explain why the actual power delivered to the lightbulb cannot be 75 W in this situation. (b) Draw a circuit diagram. (c) Find the actual power delivered to the lightbulb in this circuit.
- 7.** What is the equivalent resistance of the combination of identical resistors between points a and b in Figure P28.7?

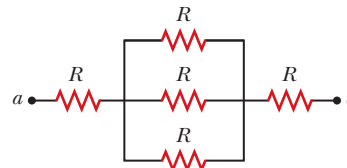

Figure P28.7

- 8.** Consider the two circuits shown in Figure P28.8 in which the batteries are identical. The resistance of each lightbulb is R . Neglect the internal resistances of the batteries. (a) Find expressions for the currents in each lightbulb. (b) How does the brightness of B compare with that of C? Explain. (c) How does the brightness of A compare with that of B and of C? Explain.

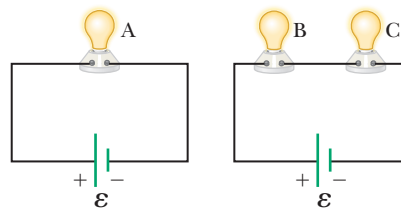

Figure P28.8

- 9.** Consider the circuit shown in Figure P28.9. Find (a) the current in the $20.0\text{-}\Omega$ resistor and (b) the potential difference between points a and b .

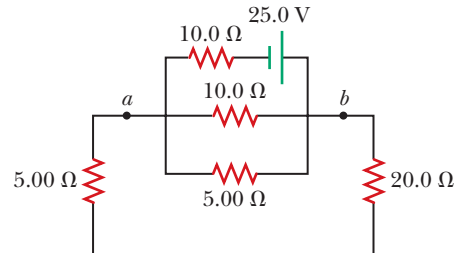

Figure P28.9

- 10.** (a) You need a $45\text{-}\Omega$ resistor, but the stockroom has only $20\text{-}\Omega$ and $50\text{-}\Omega$ resistors. How can the desired resistance be achieved under these circumstances? (b) What can you do if you need a $35\text{-}\Omega$ resistor?
- 11.** A battery with $\mathcal{E} = 6.00\ \text{V}$ and no internal resistance supplies current to the circuit shown in Figure P28.11. When the double-throw switch S is open as shown in the figure, the current in the battery is 1.00 mA. When the switch is closed in position a , the current in the

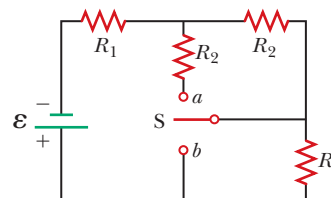

Figure P28.11

Problems 11 and 12.

battery is 1.20 mA. When the switch is closed in position b , the current in the battery is 2.00 mA. Find the resistances (a) R_1 , (b) R_2 , and (c) R_3 .

12. A battery with emf \mathcal{E} and no internal resistance supplies current to the circuit shown in Figure P28.11. When the double-throw switch S is open as shown in the figure, the current in the battery is I_0 . When the switch is closed in position a , the current in the battery is I_a . When the switch is closed in position b , the current in the battery is I_b . Find the resistances (a) R_1 , (b) R_2 , and (c) R_3 .

13. (a) Find the equivalent resistance between points a and b in Figure P28.13. (b) Calculate the current in each resistor if a potential difference of 34.0 V is applied between points a and b .

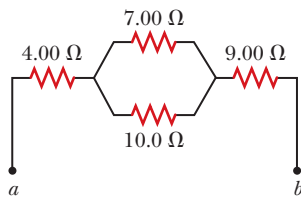

Figure P28.13

14. (a) When the switch S in the circuit of Figure P28.14 is closed, will the equivalent resistance between points a and b increase or decrease? State your reasoning. (b) Assume the equivalent resistance drops by 50.0% when the switch is closed. Determine the value of R .

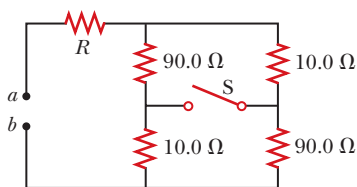

Figure P28.14

15. Two resistors connected in series have an equivalent resistance of 690 Ω . When they are connected in parallel, their equivalent resistance is 150 Ω . Find the resistance of each resistor.
16. Four resistors are connected to a battery as shown in Figure P28.16. (a) Determine the potential difference across each resistor in terms of \mathcal{E} . (b) Determine the current in each resistor in terms of I . (c) **What If?** If R_3 is increased, explain what happens to the current in each of the resistors. (d) In the limit that $R_3 \rightarrow \infty$, what are the new values of the current in each resistor in terms of I , the original current in the battery?

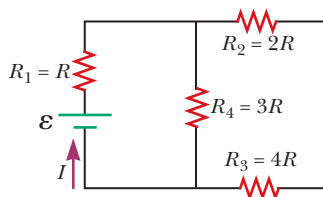

Figure P28.16

17. Consider the combination of resistors shown in Figure P28.17. (a) Find the equivalent resistance between points a and b . (b) If a voltage of 35.0 V is applied between points a and b , find the current in each resistor.

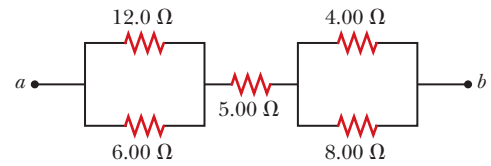

Figure P28.17

18. For the purpose of measuring the electric resistance of shoes through the body of the wearer standing on a metal ground plate, the American National Standards Institute (ANSI) specifies the circuit shown in Figure P28.18. The potential difference ΔV across the 1.00-M Ω resistor is measured with an ideal voltmeter. (a) Show that the resistance of the footwear is

$$R_{\text{shoes}} = \frac{50.0 \text{ V} - \Delta V}{\Delta V}$$

- (b) In a medical test, a current through the human body should not exceed 150 μA . Can the current delivered by the ANSI-specified circuit exceed 150 μA ? To decide, consider a person standing barefoot on the ground plate.

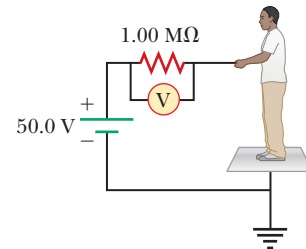

Figure P28.18

19. Calculate the power delivered to each resistor in the circuit shown in Figure P28.19.

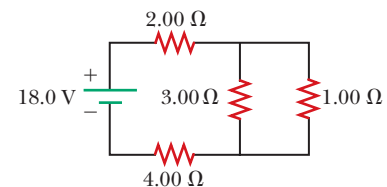

Figure P28.19

20. Why is the following situation impossible? A technician is testing a circuit that contains a resistance R . He realizes that a better design for the circuit would include a resistance $\frac{7}{3}R$ rather than R . He has three additional resistors, each with resistance R . By combining these additional resistors in a certain combination that is then placed in series with the original resistor, he achieves the desired resistance.

21. Consider the circuit shown in Figure P28.21 on page 860. (a) Find the voltage across the 3.00- Ω resistor. (b) Find the current in the 3.00- Ω resistor.

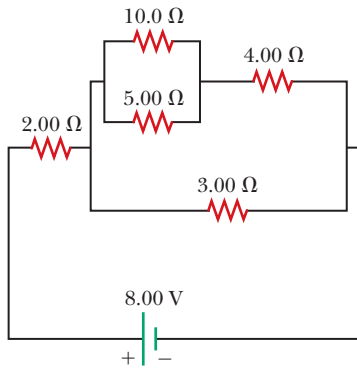

Figure P28.21

Section 28.3 Kirchhoff's Rules

22. In Figure P28.22, show how to add just enough ammeters to measure every different current. Show how to add just enough voltmeters to measure the potential difference across each resistor and across each battery.

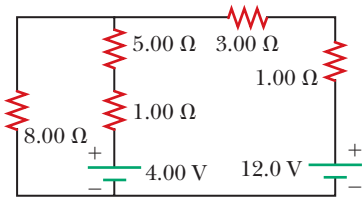

Figure P28.22 Problems 22 and 23.

23. The circuit shown in Figure P28.22 is connected for 2.00 min. (a) Determine the current in each branch of the circuit. (b) Find the energy delivered by each battery. (c) Find the energy delivered to each resistor. (d) Identify the type of energy storage transformation that occurs in the operation of the circuit. (e) Find the total amount of energy transformed into internal energy in the resistors.

24. For the circuit shown in Figure P28.24, calculate (a) the current in the 2.00-Ω resistor and (b) the potential difference between points *a* and *b*.

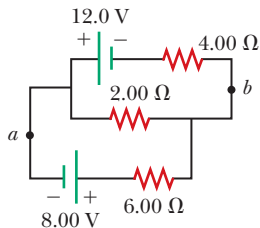

Figure P28.24

25. What are the expected readings of (a) the ideal ammeter and (b) the ideal voltmeter in Figure P28.25?

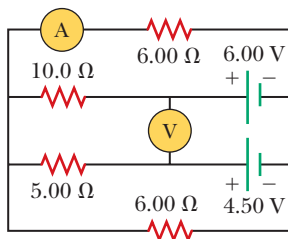

Figure P28.25

26. The following equations describe an electric circuit:

$$\begin{aligned}
 -I_1 (220 \, \Omega) + 5.80 \, \text{V} - I_2 (370 \, \Omega) &= 0 \\
 +I_2 (370 \, \Omega) + I_3 (150 \, \Omega) - 3.10 \, \text{V} &= 0 \\
 I_1 + I_3 - I_2 &= 0
 \end{aligned}$$

(a) Draw a diagram of the circuit. (b) Calculate the unknowns and identify the physical meaning of each unknown.

27. Taking $R = 1.00 \, \text{k}\Omega$ and $\mathcal{E} = 250 \, \text{V}$ in Figure P28.27, determine the direction and magnitude of the current in the horizontal wire between *a* and *e*.

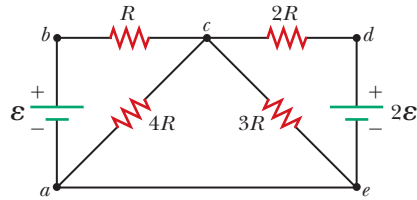

Figure P28.27

28. Jumper cables are connected from a fresh battery in one car to charge a dead battery in another car. Figure P28.28 shows the circuit diagram for this situation. While the cables are connected, the ignition switch of the car with the dead battery is closed and the starter is activated to start the engine. Determine the current in (a) the starter and (b) the dead battery. (c) Is the dead battery being charged while the starter is operating?

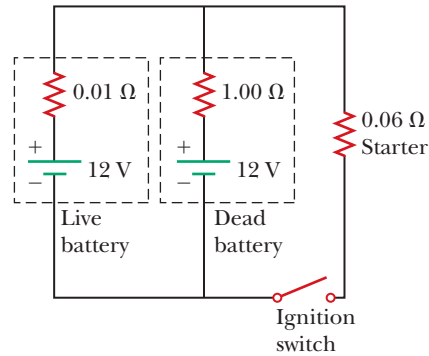

Figure P28.28

29. The ammeter shown in Figure P28.29 reads 2.00 A. Find (a) I_1 , (b) I_2 , and (c) \mathcal{E} .

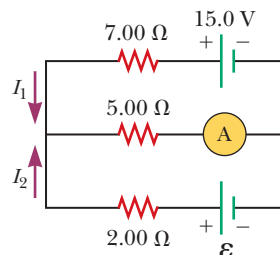

Figure P28.29

30. In the circuit of Figure P28.30, determine (a) the current in each resistor and (b) the potential difference across the 200-Ω resistor.

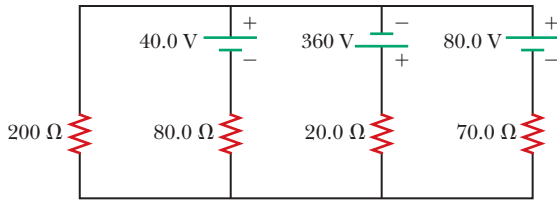

Figure P28.30

31. Using Kirchhoff's rules, (a) find the current in each resistor shown in Figure P28.31 and (b) find the potential difference between points c and f .

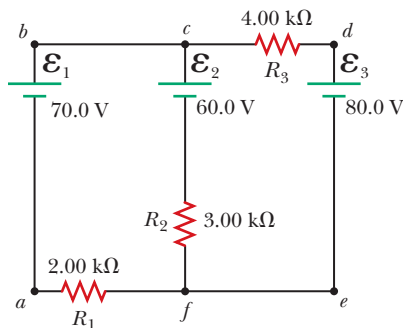

Figure P28.31

32. In the circuit of Figure P28.32, the current $I_1 = 3.00$ A and the values of \mathcal{E} for the ideal battery and R are unknown. What are the currents (a) I_2 and (b) I_3 ? (c) Can you find the values of \mathcal{E} and R ? If so, find their values. If not, explain.

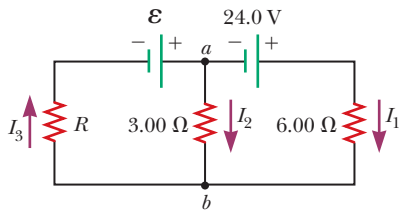

Figure P28.32

33. In Figure P28.33, find (a) the current in each resistor and (b) the power delivered to each resistor.

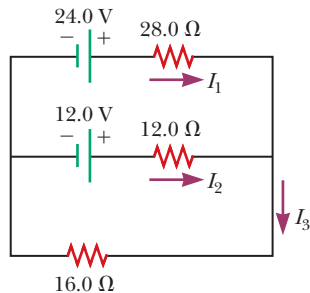

Figure P28.33

34. For the circuit shown in Figure P28.34, we wish to find the currents I_1 , I_2 , and I_3 . Use Kirchhoff's rules to obtain equations for (a) the upper loop, (b) the lower

loop, and (c) the junction on the left side. In each case, suppress units for clarity and simplify, combining the terms. (d) Solve the junction equation for I_3 . (e) Using the equation found in part (d), eliminate I_3 from the equation found in part (b). (f) Solve the equations found in parts (a) and (e) simultaneously for the two unknowns I_1 and I_2 . (g) Substitute the answers found in part (f) into the junction equation found in part (d), solving for I_3 . (h) What is the significance of the negative answer for I_2 ?

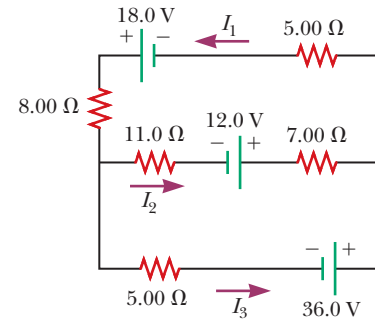

Figure P28.34

35. Find the potential difference across each resistor in Figure P28.35.

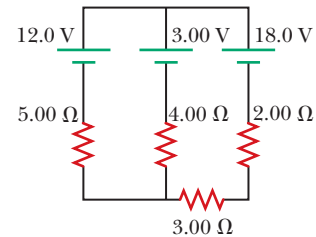

Figure P28.35

36. (a) Can the circuit shown in Figure P28.36 be reduced to a single resistor connected to a battery? Explain. Calculate the currents (b) I_1 , (c) I_2 , and (d) I_3 .

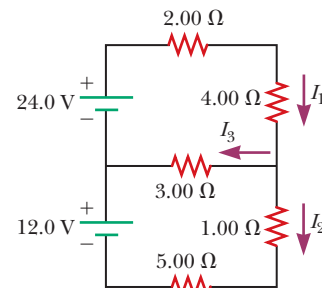

Figure P28.36

Section 28.4 RC Circuits

37. An uncharged capacitor and a resistor are connected in series to a source of emf. If $\mathcal{E} = 9.00$ V, $C = 20.0$ μ F, and $R = 100$ Ω , find (a) the time constant of the circuit, (b) the maximum charge on the capacitor, and (c) the charge on the capacitor at a time equal to one time constant after the battery is connected.

- 38.** Consider a series RC circuit as in Figure P28.38 for which $R = 1.00 \text{ M}\Omega$, $C = 5.00 \text{ }\mu\text{F}$, and $\mathcal{E} = 30.0 \text{ V}$. Find (a) the time constant of the circuit and (b) the maximum charge on the capacitor after the switch is thrown closed. (c) Find the current in the resistor 10.0 s after the switch is closed.

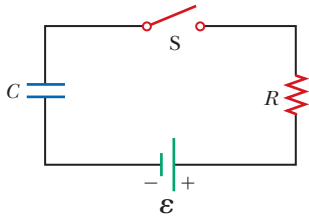

Figure P28.38

Problems 38, 67, and 68.

- 39.** A 2.00-nF capacitor with an initial charge of $5.10 \text{ }\mu\text{C}$ is discharged through a $1.30\text{-k}\Omega$ resistor. (a) Calculate the current in the resistor $9.00 \text{ }\mu\text{s}$ after the resistor is connected across the terminals of the capacitor. (b) What charge remains on the capacitor after $8.00 \text{ }\mu\text{s}$? (c) What is the maximum current in the resistor?

- 40.** A $10.0\text{-}\mu\text{F}$ capacitor is charged by a 10.0-V battery through a resistance R . The capacitor reaches a potential difference of 4.00 V in a time interval of 3.00 s after charging begins. Find R .

- 41.** In the circuit of Figure P28.41, the switch S has been open for a long time. It is then suddenly closed. Take $\mathcal{E} = 10.0 \text{ V}$, $R_1 = 50.0 \text{ k}\Omega$, $R_2 = 100 \text{ k}\Omega$, and $C = 10.0 \text{ }\mu\text{F}$. Determine the time constant (a) before the switch is closed and (b) after the switch is closed. (c) Let the switch be closed at $t = 0$. Determine the current in the switch as a function of time.

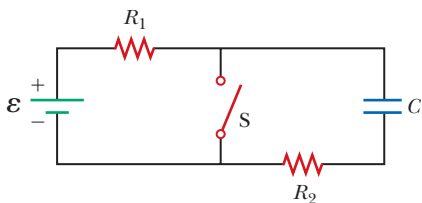

Figure P28.41 Problems 41 and 42.

- 42.** In the circuit of Figure P28.41, the switch S has been open for a long time. It is then suddenly closed. Determine the time constant (a) before the switch is closed and (b) after the switch is closed. (c) Let the switch be closed at $t = 0$. Determine the current in the switch as a function of time.

- 43.** The circuit in Figure P28.43 has been connected for a long time. (a) What is the potential difference across the capacitor? (b) If the battery is disconnected from the circuit, over what time interval does the capacitor discharge to one-tenth its initial voltage?

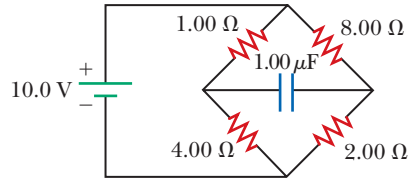

Figure P28.43

- 44.** Show that the integral $\int_0^\infty e^{-2t/RC} dt$ in Example 28.11 has the value $\frac{1}{2}RC$.
- 45.** A charged capacitor is connected to a resistor and switch as in Figure P28.45. The circuit has a time constant of 1.50 s . Soon after the switch is closed, the charge on the capacitor is 75.0% of its initial charge. (a) Find the time interval required for the capacitor to reach this charge. (b) If $R = 250 \text{ k}\Omega$, what is the value of C ?

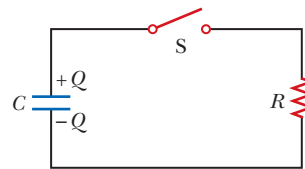

Figure P28.45

Section 28.5 Household Wiring and Electrical Safety

- 46.** An electric heater is rated at $1.50 \times 10^3 \text{ W}$, a toaster at 750 W , and an electric grill at $1.00 \times 10^3 \text{ W}$. The three appliances are connected to a common 120-V household circuit. (a) How much current does each draw? (b) If the circuit is protected with a 25.0-A circuit breaker, will the circuit breaker be tripped in this situation? Explain your answer.

- 47.** A heating element in a stove is designed to receive 3000 W when connected to 240 V . (a) Assuming the resistance is constant, calculate the current in the heating element if it is connected to 120 V . (b) Calculate the power it receives at that voltage.

- 48.** Turn on your desk lamp. Pick up the cord, with your thumb and index finger spanning the width of the cord. (a) Compute an order-of-magnitude estimate for the current in your hand. Assume the conductor inside the lamp cord next to your thumb is at potential $\sim 10^2 \text{ V}$ at a typical instant and the conductor next to your index finger is at ground potential (0 V). The resistance of your hand depends strongly on the thickness and the moisture content of the outer layers of your skin. Assume the resistance of your hand between fingertip and thumb tip is $\sim 10^4 \text{ }\Omega$. You may model the cord as having rubber insulation. State the other quantities you measure or estimate and their values. Explain your reasoning. (b) Suppose your body is isolated from any other charges or currents. In order-of-magnitude terms, estimate the potential difference between your thumb where it contacts the cord and your finger where it touches the cord.

Additional Problems

49. Assume you have a battery of emf \mathcal{E} and three identical lightbulbs, each having constant resistance R . What is the total power delivered by the battery if the lightbulbs are connected (a) in series and (b) in parallel? (c) For which connection will the lightbulbs shine the brightest?
50. Find the equivalent resistance between points a and b in Figure P28.50.

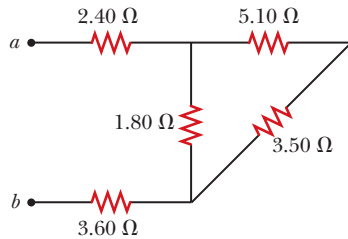

Figure P28.50

51. Four 1.50-V AA batteries in series are used to power a small radio. If the batteries can move a charge of 240 C, how long will they last if the radio has a resistance of 200 Ω ?
52. Four resistors are connected in parallel across a 9.20-V battery. They carry currents of 150 mA, 45.0 mA, 14.0 mA, and 4.00 mA. If the resistor with the largest resistance is replaced with one having twice the resistance, (a) what is the ratio of the new current in the battery to the original current? (b) **What If?** If instead the resistor with the smallest resistance is replaced with one having twice the resistance, what is the ratio of the new total current to the original current? (c) On a February night, energy leaves a house by several energy leaks, including 1.50×10^3 W by conduction through the ceiling, 450 W by infiltration (airflow) around the windows, 140 W by conduction through the basement wall above the foundation sill, and 40.0 W by conduction through the plywood door to the attic. To produce the biggest saving in heating bills, which one of these energy transfers should be reduced first? Explain how you decide. Clifford Swartz suggested the idea for this problem.
53. The circuit in Figure P28.53 has been connected for several seconds. Find the current (a) in the 4.00-V bat-

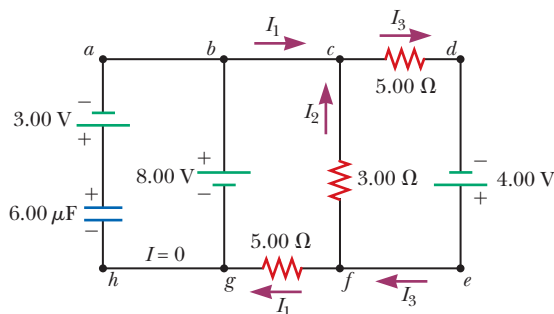

Figure P28.53

tery, (b) in the 3.00- Ω resistor, (c) in the 8.00-V battery, and (d) in the 3.00-V battery. (e) Find the charge on the capacitor.

54. The circuit in Figure P28.54a consists of three resistors and one battery with no internal resistance. (a) Find the current in the 5.00- Ω resistor. (b) Find the power delivered to the 5.00- Ω resistor. (c) In each of the circuits in Figures P28.54b, P28.54c, and P28.54d, an additional 15.0-V battery has been inserted into the circuit. Which diagram or diagrams represent a circuit that requires the use of Kirchhoff's rules to find the currents? Explain why. (d) In which of these three new circuits is the smallest amount of power delivered to the 10.0- Ω resistor? (You need not calculate the power in each circuit if you explain your answer.)

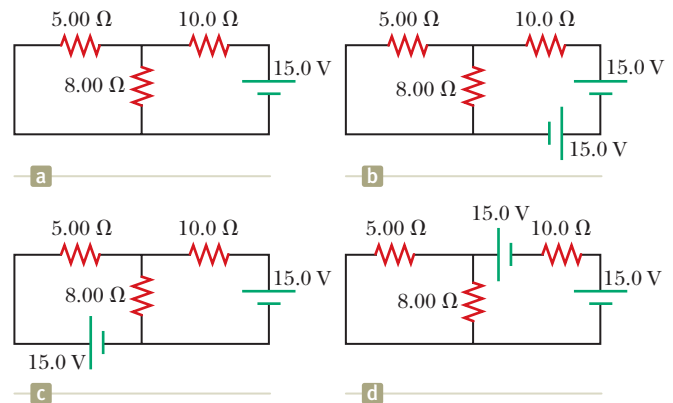

Figure P28.54

55. For the circuit shown in Figure P28.55, the ideal voltmeter reads 6.00 V and the ideal ammeter reads 3.00 mA. Find (a) the value of R , (b) the emf of the battery, and (c) the voltage across the 3.00-k Ω resistor.

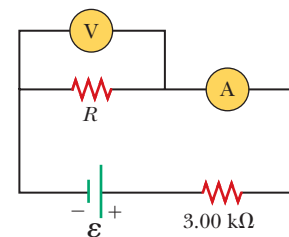

Figure P28.55

56. The resistance between terminals a and b in Figure P28.56 is 75.0 Ω . If the resistors labeled R have the same value, determine R .

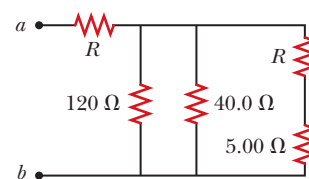

Figure P28.56