

CHAPTER QUIZ

1. Technician A says that a pickup coil (pulse generator) can be tested with an ohmmeter. Technician B says that ignition coils can be tested with an ohmmeter. Which technician is correct?
a. Technician A only c. Both Technicians A and B
b. Technician B only d. Neither Technician A nor B
2. Technician A says that a defective spark plug wire can cause an engine misfire. Technician B says that a defective spark plug can cause an engine misfire. Which technician is correct?
a. Technician A only
b. Technician B only
c. Both Technicians A and B
d. Neither Technician A nor B
3. A spark tester should be used to check for spark because _____.
a. A spark tester requires at least 25,000 volts to fire
b. It is connected to the CKP sensor to check its output
c. It can detect a cracked spark plug
d. It can detect the gap of the spark plugs
4. Typical primary coil resistance specifications usually range from _____ ohms.
a. 100 to 450 c. 0.5 to 3
b. 500 to 1,500 d. 6,000 to 30,000
5. Typical secondary coil resistance specifications usually range from _____ ohms.
a. 100 to 450 c. 1 to 3
b. 500 to 1,500 d. 6,000 to 30,000
6. A coil is being tested using current ramping. The waveform should _____.
a. Slope downward
b. Slope upward
c. Remain flat
d. Start off flat then slope upward
7. Camshaft variation as displayed on a scan tool on an engine with a distributor-mounted CMP sensor should be \pm _____ degrees.
a. 10 c. 2
b. 5 d. None of the above
8. The spark plug threads in the cylinder head should be cleaned using a(n) _____ before installing new plugs.
a. Wire brush c. Old toothbrush
b. Tap d. Thread chaser
9. Two technicians are discussing a no-start condition. During cranking, a magnet held over the coil moves and the engine backfires at times. Technician A says that a bad pickup coil or CKP sensor is the most likely cause. Technician B says that an open coil primary is the most likely cause. Which technician is correct?
a. Technician A only c. Both Technicians A and B
b. Technician B only d. Neither Technician A nor B
10. Which sensor produces a digital signal?
a. Magnetic sensor c. Pickup coil
b. Hall-effect sensor d. Both b and c

chapter 71

COMPUTER FUNDAMENTALS

OBJECTIVES: After studying Chapter 71, the reader will be able to: • Prepare for ASE Electrical/Electronic Systems (A6) certification test content area “A” (General Electrical/Electronic Systems Diagnosis). • Explain the purpose and function of onboard computers. • List the various parts of an automotive computer. • List input sensors. • List output devices (actuators) controlled by the computer.

KEY TERMS: Actuator 814 • Analog-to-digital (AD) converter 813 • Baud rate 815 • Binary system 816 • Clock generator 815 • Controller 812 • CPU 814 • Digital computer 814 • Duty cycle 817 • E²PROM 813 • ECA 812 • ECM 812 • ECU 812 • EEPROM 813 • Engine mapping 814 • Input 813 • Input conditioning 813 • KAM 814 • Nonvolatile RAM 814 • Output drivers 816 • Powertrain control module (PCM) 812 • PROM 813 • PWM 817 • RAM 814 • ROM 813 • SAE 812

COMPUTER FUNDAMENTALS

PURPOSE AND FUNCTION Modern automotive control systems consist of a network of electronic sensors, actuators, and computer modules designed to regulate the powertrain and vehicle support

systems. The onboard automotive computer has many names. It may be called an **electronic control unit (ECU)**, **electronic control module (ECM)**, **electronic control assembly (ECA)**, or a **controller**, depending on the manufacturer and the computer application. The **Society of Automotive Engineers (SAE)** bulletin J1930 standardizes the name as a **powertrain control module (PCM)**. The PCM coordinates engine and transmission operation, processes data, maintains

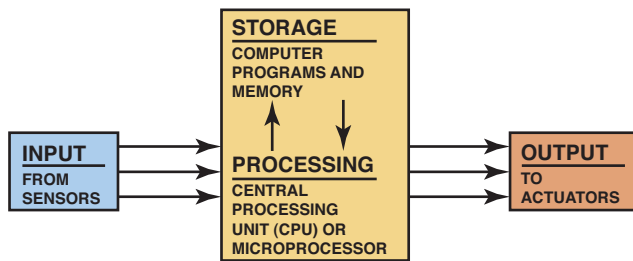

FIGURE 71-1 All computer systems perform four basic functions: input, processing, storage, and output.

communications, and makes the control decisions needed to keep the vehicle operating. Not only is it capable of operating the engine and transmission, but it is also able to perform the following:

- Undergo self-tests (40% of the computing power is devoted to diagnosis)
- Set and store diagnostic trouble codes (DTCs)
- Communicate with the technician using a scan tool

VOLTAGE SIGNALS Automotive computers use voltage to send and receive information. Voltage is electrical pressure and does not flow through circuits, but voltage can be used as a signal. A computer converts input information or data into voltage signal combinations that represent number combinations. A computer processes the input voltage signals it receives by computing what they represent, and then delivering the data in computed or processed form.

COMPUTER FUNCTIONS

BASIC FUNCTIONS The operation of every computer can be divided into four basic functions. ● **SEE FIGURE 71-1.**

- **Input.** Receives voltage signals from sensors
- **Processing.** Performs mathematical calculations
- **Storage.** Includes short-term and long-term memory
- **Output.** Controls an output device by either turning it on or off

INPUT FUNCTIONS First, the computer receives a voltage signal (input) from an input device. **Input** is a signal from a device that can be as simple as a button or a switch on an instrument panel, or a sensor on an automotive engine. ● **SEE FIGURE 71-2** for a typical type of automotive sensor.

Vehicles use various mechanical, electrical, and magnetic sensors to measure factors such as vehicle speed, throttle position, engine RPM, air pressure, oxygen content of exhaust gas, airflow, engine coolant temperature, and status of electrical circuits (on-off). Each sensor transmits its information in the form of voltage signals. The computer receives these voltage signals, but before it can use them, the signals must undergo a process called **input conditioning**. This process includes amplifying voltage signals that are too small for the computer circuitry to handle. Input conditioners generally are located inside the computer, but a few sensors have their own input conditioning circuitry.

A digital computer changes the analog input signals (voltage) to digital bits (*binary digits*) of information through an **analog-to-digital (AD) converter** circuit. The binary digital number is used by the computer in its calculations or logic networks. ● **SEE FIGURE 71-3.**

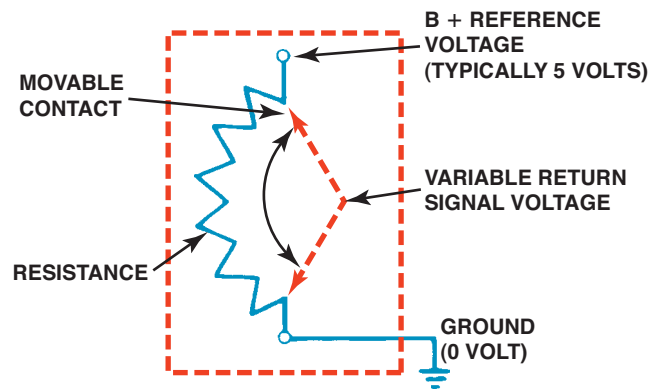

FIGURE 71-2 A potentiometer uses a movable contact to vary resistance and send an analog voltage right to the PCM.

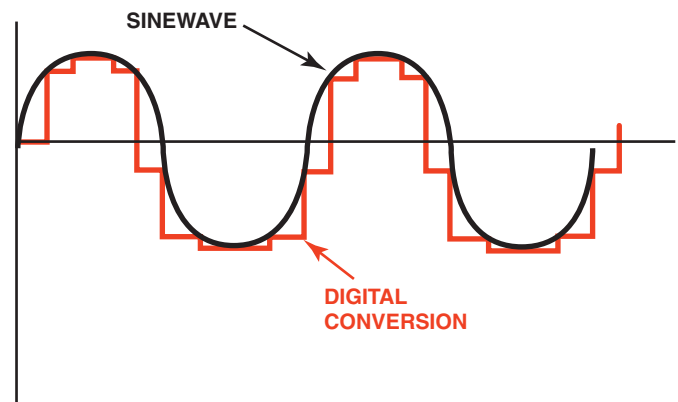

FIGURE 71-3 An AD converter changes analog (variable) voltage signals into digital signals that the PCM can process.

PROCESSING The term *processing* is used to describe how input voltage signals received by a computer are handled through a series of electronic logic circuits maintained in its programmed instructions. These logic circuits change the input voltage signals, or data, into output voltage signals or commands.

STORAGE Storage is the place where the program instructions for a computer are stored in electronic memory. Some programs may require that certain input data be stored for later reference or future processing. In others, output commands may be delayed or stored before they are transmitted to devices elsewhere in the system.

Computers have two types of memory.

1. Permanent memory is called **read-only memory (ROM)** because the computer can only read the contents; it cannot change the data stored in it. This data is retained even when power to the computer is shut off. Part of the ROM is built into the computer, and the rest is located in an integrated circuit (IC) chip called a **programmable read-only memory (PROM)** or calibration assembly. Many chips are erasable, meaning that the program can be changed. These chips are called erasable programmable read-only memory, or EPROM. Since the early 1990s, most programmable memory has been electronically erasable, meaning that the program in the chip can be reprogrammed by using a scan tool and the proper software. This computer reprogramming is usually called *reflashing*. These chips are electrically erasable programmable read-only memory, abbreviated **EEPROM** or **E²PROM**.

All vehicles equipped with onboard diagnosis second generation, called OBD-II, are equipped with EEPROMs.

2. Temporary memory is called **random-access memory (RAM)**, because the computer can write or store new data into it as directed by the computer program, as well as read the data already in it. Automotive computers use two types of RAM memory.

- Volatile RAM memory is lost whenever the ignition is turned off. However, a type of volatile RAM called **keep-alive memory (KAM)** can be wired directly to battery power. This prevents its data from being erased when the ignition is turned off. One example of RAM and KAM is the loss of station settings in a programmable radio when the battery is disconnected. Because all the settings are stored in RAM, they have to be reset when the battery is reconnected. System trouble codes are commonly stored in RAM and can be erased by disconnecting the battery.
- **Nonvolatile RAM** memory can retain its information even when the battery is disconnected. One use for this type of RAM is the storage of odometer information in an electronic speedometer. The memory chip retains the mileage accumulated by the vehicle. When speedometer replacement is necessary, the odometer chip is removed and installed in the new speedometer unit. KAM is used primarily in conjunction with adaptive strategies.

OUTPUT FUNCTIONS After the computer has processed the input signals, it sends voltage signals or commands to other devices in the system, such as system actuators. An **actuator** is an electrical or mechanical output device that converts electrical energy into a mechanical action, such as:

- Adjusting engine idle speed
- Operating fuel injectors
- Ignition timing control
- Altering suspension height

COMPUTER COMMUNICATION A typical vehicle can have many computers, also called modules or controllers. Computers also can communicate with, and control, each other through their output and input functions. This means that the output signal from one computer system can be the input signal for another computer system through a data network. See Chapter 14 for details on network communications.

DIGITAL COMPUTERS

PARTS OF A COMPUTER The software consists of the programs and logic functions stored in the computer's circuitry. The hardware is the mechanical and electronic parts of a computer.

- **Central processing unit.** The microprocessor is the **central processing unit (CPU)** of a computer. Because it performs the essential mathematical operations and logic decisions that make up its processing function, the CPU can be considered the brain of a computer. Some computers use more than one microprocessor, called a coprocessor. The digital computer can process thousands of digital signals per second because its circuits are able to switch voltage signals

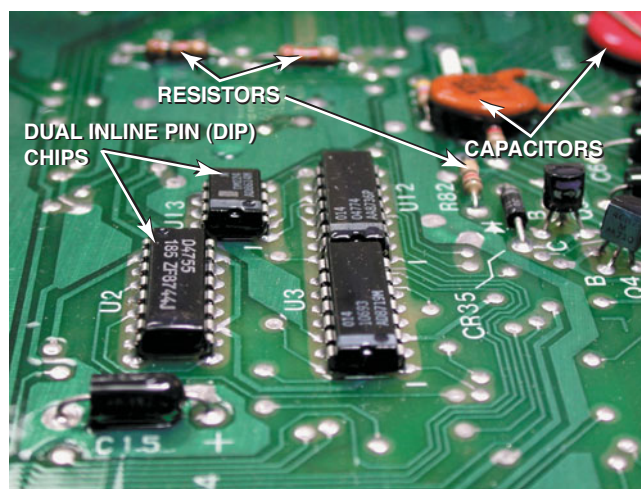

FIGURE 71-4 Many electronic components are used to construct a typical vehicle computer including chips, resistors, and capacitors.

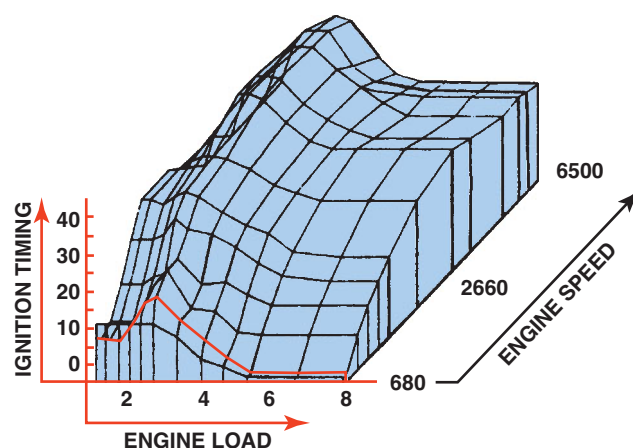

FIGURE 71-5 Typical engine map developed from testing and used by the vehicle computer to provide the optimum ignition timing for all engine speeds and load combinations.

on and off in billionths of a second. It is called a **digital computer** because it processes zeros and ones (digits) and needs to have any variable input signals, called analog inputs, converted to digital form before it can function. ● **SEE FIGURE 71-4.**

- **Computer memory.** Other integrated circuit (IC) devices store the computer operating program, system sensor input data, and system actuator output data—information that is necessary for CPU operation.
- **Computer programs.** By operating a vehicle on a dynamometer and manually adjusting the variable factors such as speed, load, and spark timing, it is possible to determine the optimum output settings for the best driveability, economy, and emission control. This is called engine mapping. ● **SEE FIGURE 71-5.**

Engine mapping creates a three-dimensional performance graph that applies to a given vehicle and powertrain combination. Each combination is mapped in this manner to produce a PROM or EEPROM calibration. This allows an automaker to use one basic computer for all models.

Many older-vehicle computers used a single PROM that plugged into the computer.

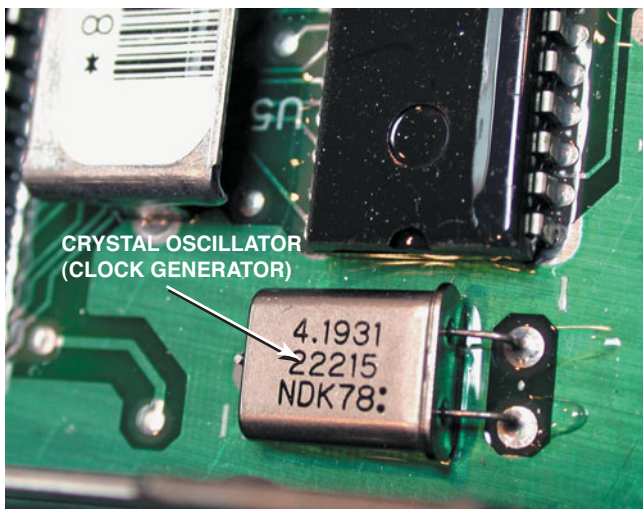

FIGURE 71-6 The clock generator produces a series of pulses that are used by the microprocessor and other components to stay in step with each other at a steady rate.

NOTE: If the computer needs to be replaced, the PROM or calibration module must be removed from the defective unit and installed in the replacement computer. Since the mid-1990s, PCMs do not have removable calibration PROMs, and must be programmed or flashed using a scan tool before being put into service.

CLOCK RATES AND TIMING The microprocessor receives sensor input voltage signals, processes them by using information from other memory units, and then sends voltage signals to the appropriate actuators. The microprocessor communicates by transmitting long strings of 0s and 1s in a language called binary code; but the microprocessor must have some way of knowing when one signal ends and another begins. That is the job of a crystal oscillator called a **clock generator**. ● **SEE FIGURE 71-6.**

The computer's crystal oscillator generates a steady stream of one-bit-long voltage pulses. Both the microprocessor and the memories monitor the clock pulses while they are communicating. Because they know how long each voltage pulse should be, they can distinguish between a 01 and a 0011. To complete the process, the input and output circuits also watch the clock pulses.

COMPUTER SPEEDS Not all computers operate at the same speed; some are faster than others. The speed at which a computer operates is specified by the cycle time, or clock speed, required to perform certain measurements. Cycle time or clock speed is measured in megahertz (4.7 MHz, 8 MHz, 15 MHz, 18 MHz, and 32 Hz, which is the clock speed of most vehicle computers today).

BAUD RATE The computer transmits bits of a serial data-stream at precise intervals. The computer's speed is called the **baud rate**, or bits per second. The term *baud* was named after J. M. Emile Baudot (1845–1903), a French telegraph operator who developed a five-bit-per-character code of telegraph. Just as mph helps in estimating the length of time required to travel a certain distance, the baud rate is useful in estimating how long a given computer will need to transmit a specified amount of data to another computer.

Automotive computers have evolved from a baud rate of 160 used in the early 1980s to a baud rate as high as 500,000 for some

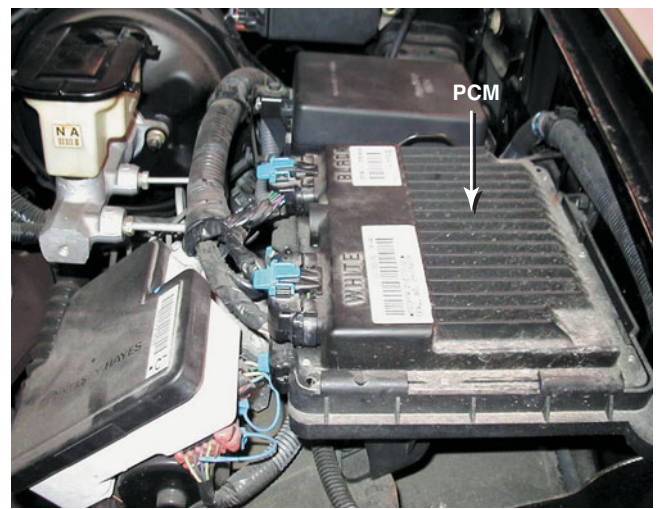

FIGURE 71-7 This powertrain control module (PCM) is located under the hood on this Chevrolet pickup truck.

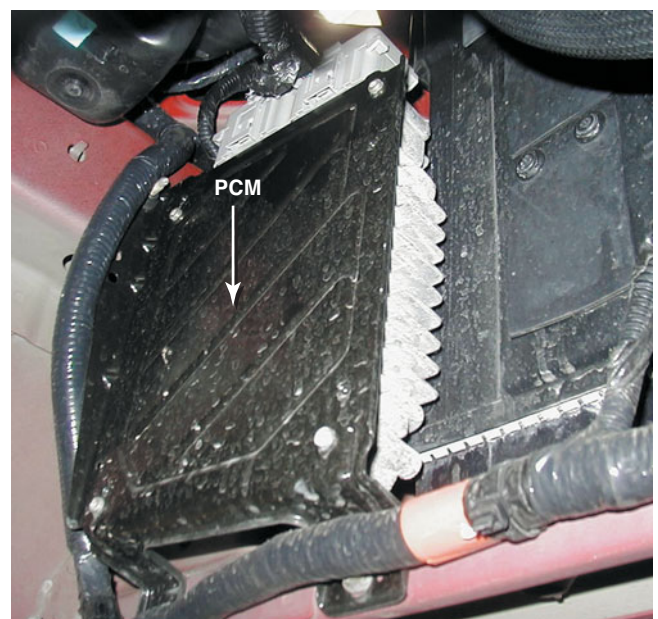

FIGURE 71-8 This PCM on a Chrysler vehicle can only be seen by hoisting the vehicle, because it is located next to the radiator and in the airflow to help keep it cool.

networks. The speed of data transmission is an important factor both in system operation and in system troubleshooting.

CONTROL MODULE LOCATIONS The computer hardware is all mounted on one or more circuit boards and installed in a metal case to help shield it from electromagnetic interference (EMI). The wiring harnesses that link the computer to sensors and actuators connect to multipin connectors or edge connectors on the circuit boards.

Onboard computers range from single-function units that control a single operation to multifunction units that manage all of the separate (but linked) electronic systems in the vehicle. They vary in size from a small module to a notebook-size box. Most other engine computers are installed in the passenger compartment either under the instrument panel or in a side kick panel where they can be shielded from physical damage caused by temperature extremes, dirt, and vibration, or interference by the high currents and voltages of various underhood systems. ● **SEE FIGURES 71-7 AND 71-8.**



FREQUENTLY ASKED QUESTION

What Is a Binary System?

In a digital computer the signals are simple high-low, yes-no, on-off signals. The digital signal voltage is limited to two voltage levels: high voltage and low voltage. Since there is no stepped range of voltage or current in between, a digital binary signal is a “square wave.” The signal is called “digital” because the on and off signals are processed by the computer as the digits or numbers 0 and 1. The number system containing only these two digits is called the **binary system**. Any number or letter from any number system or language alphabet can be translated into a combination of binary 0s and 1s for the digital computer. A digital computer changes the analog input signals (voltage) to digital bits (*binary digits*) of information through an analog-to-digital (AD) converter circuit. The binary digital number is used by the computer in its calculations or logic networks. Output signals usually are digital signals that turn system actuators on and off.

COMPUTER INPUT SENSORS

The vehicle computer uses signals (voltage levels) from the following sensors.

- **Engine speed (revolutions per minute, or RPM) sensor.** This signal comes from the primary ignition signal in the ignition control module (ICM) or directly from the crankshaft position (CKP) sensor.
- **Switches or buttons for accessory operation.** Many accessories use control buttons that signal the body computer to turn on or off an accessory such as the windshield wiper or heated seats.
- **Manifold absolute pressure (MAP) sensor.** This sensor detects engine load by using a signal from a sensor that measures the vacuum in the intake manifold.
- **Mass airflow (MAF) sensor.** This sensor measures the mass (weight and density) of the air flowing through the sensor and entering the engine.
- **Engine coolant temperature (ECT) sensor.** This sensor measures the temperature of the engine coolant. This is a sensor used for engine controls and for automatic air-conditioning control operation.
- **Oxygen sensor (O2S).** This sensor measures the oxygen in the exhaust stream. There are as many as four oxygen sensors in some vehicles.
- **Throttle position (TP) sensor.** This sensor measures the throttle opening and is used by the computer for engine control and the shift points of the automotive transmission/transaxle.
- **Vehicle speed (VS) sensor.** This sensor measures the vehicle speed using a sensor located at the output of the transmission/transaxle or by monitoring sensors at the wheel speed sensors. This sensor is used by the speedometer, cruise control, and airbag systems.

COMPUTER OUTPUTS

OUTPUT CONTROLS After the computer has processed the input signals, it sends voltage signals or commands to other devices in the system, as follows:

- **Operate actuators.** An actuator is an electrical or mechanical device that converts electrical energy into heat, light, or motion to control engine idle speed, suspension height, ignition timing, and other output devices.
- **Network communication.** Computers also can communicate with another computer system through a network.

A vehicle computer can do only two things.

1. Turn a device on.
2. Turn a device off.

Typical output devices include the following:

- **Fuel injectors.** The computer can vary the amount of time in milliseconds the injectors are held open, thereby controlling the amount of fuel supplied to the engine.
- **Blower motor control.** Many blower motors are controlled by the body computer by pulsing the current on and off to maintain the desired speed.
- **Transmission shifting.** The computer provides a ground to the shift solenoids and torque converter clutch (TCC) solenoid. The operation of the automatic transmission/transaxle is optimized based on vehicle sensor information.
- **Idle speed control.** The computer can control the idle air control (IAC) or electronic throttle control (ETC) to maintain engine idle speed and to provide an increased idle speed as needed.
- **Evaporative emission control solenoids.** The computer can control the flow of gasoline fumes from the charcoal canister to the engine and seal off the system to perform a fuel system leak detection test as part of the OBD-II system requirements.

Most outputs work electrically in one of three ways:

1. Digital
2. Pulse-width modulated
3. Switched

Digital control is mostly used for computer communications and involves voltage signals that are transmitted and received in packets.

Pulse-width control allows a device, such as a blower motor, to be operated at variable speed by changing the amount of time electrical power is supplied to the device.

A switched output is an output that is either on or off. In many circuits, the PCM uses a relay to switch a device on or off, because the relay is a low-current device that can switch to a higher current device. Most computer circuits cannot handle high amounts of current. By using a relay circuit, the PCM provides the output control to the relay, which in turn provides the output control to the device.

The relay coil, which the PCM controls, typically draws less than 0.5 ampere. The device that the relay controls may draw 30 amperes or more. The PCM switches are actually transistors, and are often called **output drivers**. ● SEE FIGURE 71-9.

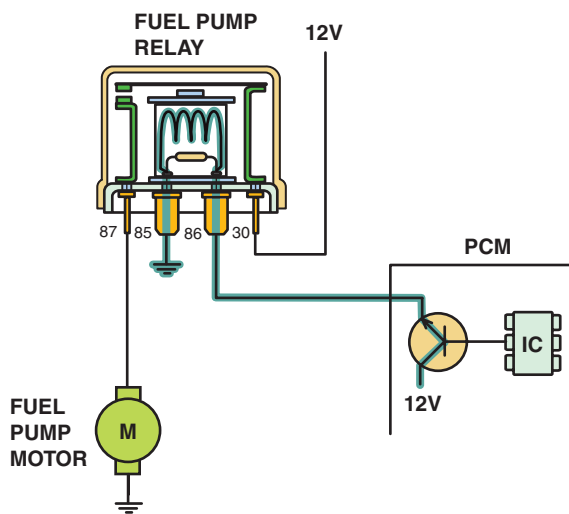

FIGURE 71-9 A typical output driver. In this case, the PCM applies voltage to the fuel pump relay coil to energize the fuel pump.

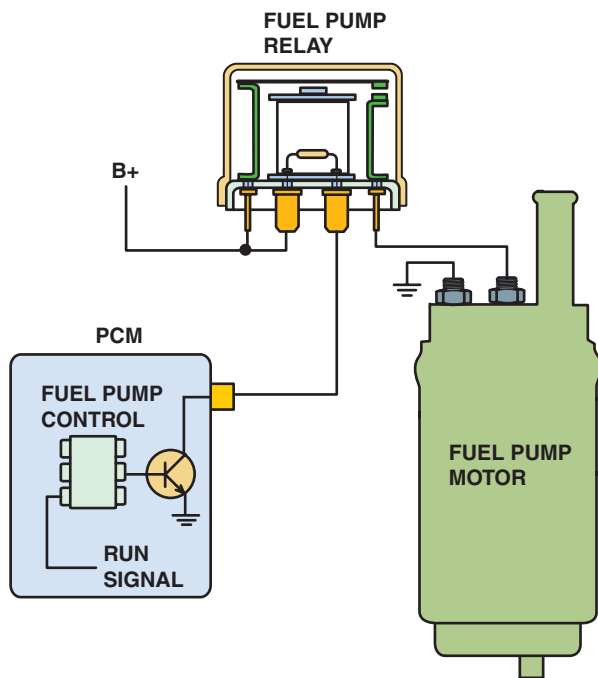

FIGURE 71-10 A typical low-side driver (LSD) which uses a control module to control the ground side of the relay coil.

OUTPUT DRIVERS There are two basic types of output drivers.

- 1. Low-side drivers.** The low-side drivers (LSDs) are transistors inside the computer that complete the ground path of relay coil. Ignition (key-on) voltage and battery voltage are supplied to the relay. The ground side of the relay coil is connected to the transistor inside the computer. In the example of a fuel pump relay, when the transistor turns “on,” it will complete the ground for the relay coil, and the relay will then complete the power circuit between the battery power and the fuel pump. A relatively low current flows through the relay coil and transistor that is inside the computer. This causes the relay to switch and provides the fuel pump with battery voltage. The majority of switched outputs have typically been low-side drivers. ● **SEE FIGURE 71-10.**

Low-side drivers can often perform a diagnostic circuit check by monitoring the voltage from the relay to check that the control circuit for the relay is complete. A low-side driver, however, cannot detect a short-to-ground.

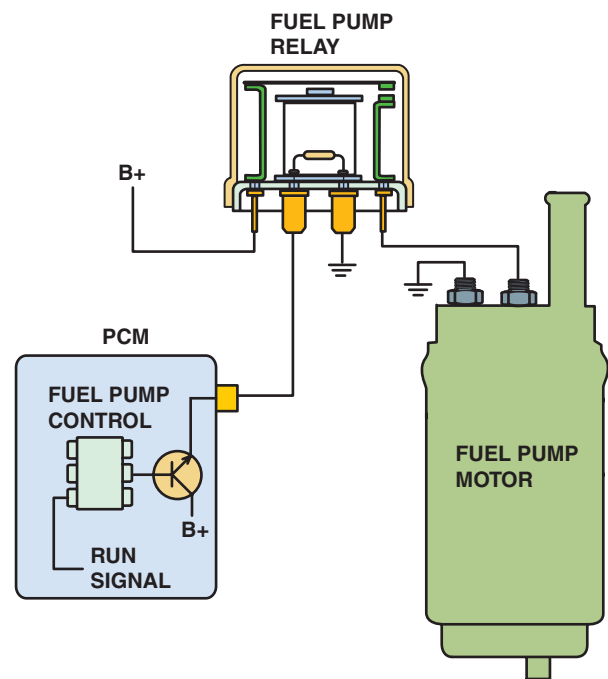

FIGURE 71-11 A typical module-controlled high-side driver (HSD) where the module itself supplies the electrical power to the device. The logic circuit inside the module can detect circuit faults including continuity of the circuit and if there is a short-to-ground in the circuit being controlled.

- 2. High-side drivers.** The high-side drivers (HSDs) control the power side of the circuit. In these applications when the transistor is switched on, voltage is applied to the device. A ground has been provided to the device so when the high-side driver switches, the device will be energized. In some applications, high-side drivers are used instead of low-side drivers to provide better circuit protection. General Motors vehicles have used a high-side driver to control the fuel pump relay instead of a low-side driver. In the event of an accident, should the circuit to the fuel pump relay become grounded, a high-side driver would cause a short circuit, which would cause the fuel pump relay to de-energize. High-side drivers inside modules can detect electrical faults such as a lack of continuity when the circuit is not energized. ● **SEE FIGURE 71-11.**

PULSE-WIDTH MODULATION Pulse-width modulation (PWM) is a method of controlling an output using a digital signal. Instead of just turning devices on or off, the computer can control the amount of on-time. For example, a solenoid could be a PWM device. If, for example, a vacuum solenoid is controlled by a switched driver, switching either on or off would mean that either full vacuum would flow through the solenoid or no vacuum would flow through the solenoid. However, to control the amount of vacuum that flows through the solenoid, pulse-width modulation could be used. A PWM signal is a digital signal, usually 0 volt and 12 volts, which is cycling at a fixed frequency. Varying the length of time that the signal is on provides a signal that can vary the on- and off-time of an output. The ratio of on-time relative to the period of the cycle is referred to as **duty cycle**. ● **SEE FIGURE 71-12.**

Depending on the frequency of the signal, which is usually fixed, this signal would turn the device on and off a fixed number of times per second. When, for example, the voltage is high (12 volts) 90% of the time and low (0 volt) the other 10% of the time, the signal has a 90% duty cycle. In other words, if this signal were applied to

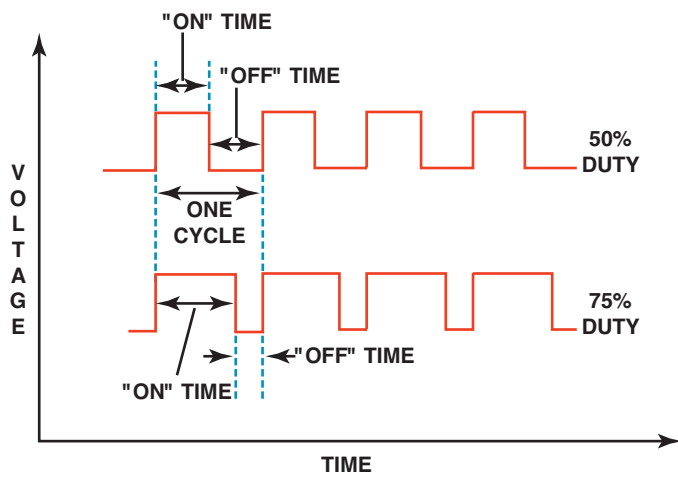

FIGURE 71-12 Both the top and bottom pattern have the same frequency. However, the amount of on-time varies. Duty cycle is the percentage of the time during a cycle that the signal is turned on.

the vacuum solenoid, the solenoid would be on 90% of the time. This would allow more vacuum to flow through the solenoid. The computer has the ability to vary this on- and off-time or pulse-width modulation at any rate between 0% and 100%. A good example of pulse-width modulation is the cooling fan speed control. The speed of the cooling fan is controlled by varying the amount of on-time that the battery voltage is applied to the cooling fan motor.

- 100% duty cycle: fan runs at full speed
- 75% duty cycle: fan runs at 3/4 speed
- 50% duty cycle: fan runs at 1/2 speed
- 25% duty cycle: fan runs at 1/4 speed

The use of PWM, therefore, results in precise control of an output device to achieve the amount of cooling needed and conserve electrical energy compared to simply timing the cooling fan on high when needed. PWM may be used to control vacuum through a solenoid, the amount of purge of the evaporative purge solenoid, the speed of a fuel pump motor, control of a linear motor, or even the intensity of a light bulb.

REVIEW QUESTIONS

1. What part of the vehicle computer is considered to be the brain?
2. What is the difference between volatile and nonvolatile RAM?
3. What are the four input sensors?
4. What are the four output devices?

CHAPTER QUIZ

1. What unit of electricity is used as a signal for a computer?
 - a. Volt
 - b. Ohm
 - c. Ampere
 - d. Watt
2. The four basic computer functions include _____.
 - a. Writing, processing, printing, and remembering
 - b. Input, processing, storage, and output
 - c. Data gathering, processing, output, and evaluation
 - d. Sensing, calculating, actuating, and processing
3. All OBD-II vehicles use what type of read-only memory?
 - a. ROM
 - b. PROM
 - c. EPROM
 - d. EEPROM
4. The "brain" of the computer is the _____.
 - a. PROM
 - b. RAM
 - c. CPU
 - d. AD converter
5. Computer speed is measured in _____.
 - a. Baud rate
 - b. Clock speed (Hz)
 - c. Voltage
 - d. Bytes
6. Which item is a computer input sensor?
 - a. RPM
 - b. Throttle position
 - c. Engine coolant temperature
 - d. All of the above
7. Which item is a computer output device?
 - a. Fuel injector
 - b. Transmission shift solenoid
 - c. Evaporative emission control solenoid
 - d. All of the above
8. The SAE term for the vehicle computer is _____.
 - a. PCM
 - b. ECM
 - c. ECA
 - d. Controller
9. What two things can a vehicle computer actually perform (output)?
 - a. Store and process information
 - b. Turn something on or turn something off
 - c. Calculate and vary temperature
 - d. Control fuel and timing only
10. Analog signals from sensors are changed to digital signals for processing by the computer through which type of circuit?
 - a. Digital
 - b. Analog
 - c. Analog-to-digital converter
 - d. PROM