

Experiment No.:4

Zener Diode Characteristics

Objective:

- To plot V-I Characteristics of Zener Diode.

Components:

Zener Diodes 1N4735A/ FZ 5.1, Resistor 1K

Equipments:

Bread board, Regulated power supply , Digital Ammeter, Digital Voltmeter, Connecting Wires.

Theory:

Zener diode is a heavily doped Silicon diode. An ideal P-N junction diode does not conduct in reverse biased condition. A Zener diode conducts excellently even in reverse biased condition. These diodes operate at a precise value of voltage called break down voltage. A Zener diode when forward biased behaves like an ordinary P-N junction diode. A Zener diode when reverse biased can undergo avalanche break down or zener break down.

Avalanche Break down:

If both p-side and n-side of the diode are lightly doped, depletion region at the junction widens. Application of a very large electric field at the junction increases the kinetic energy of the charge carriers which collides with the adjacent atoms and generates charge carriers by breaking the bond, they in-turn collides with other atoms by creating new charge carriers, this process is cumulative which results in the generation of large current resulting in Avalanche Breakdown.

Zener Break down:

If both p-side and n-side of the diode are heavily doped, depletion region at the junction reduces, it leads to the development of strong electric field and application of even a small voltage at the junction may rupture covalent bond and generate large number of

charge carriers. Such sudden increase in the number of charge carriers results in Zener break down.

Circuit Diagram:

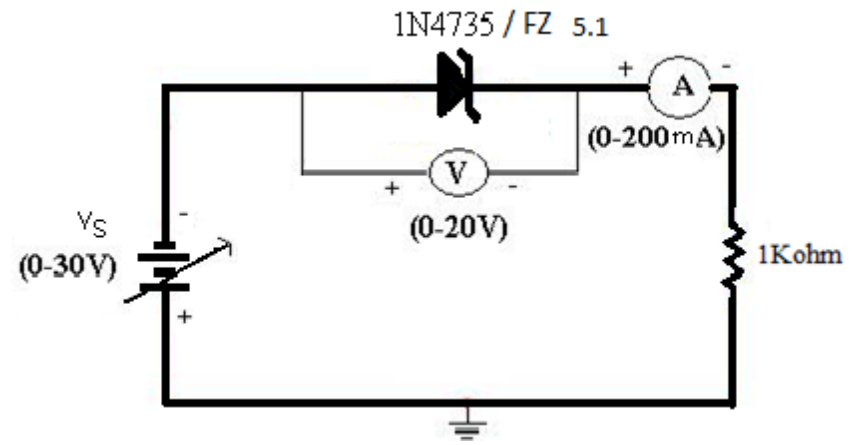

Figure 1: Forward Bias Condition

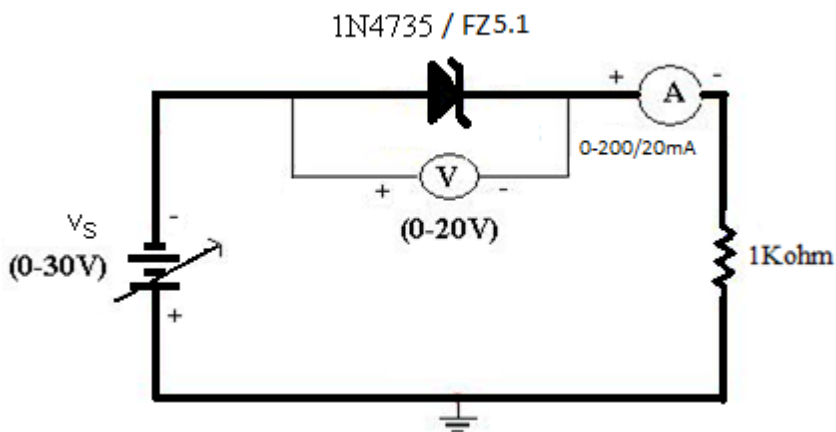

Figure 2: Reverse Bias Condition

Procedure:

Forward Bias Condition:

1. Connect the circuit as shown in fig.1.
2. Vary V_F gradually from 0 to 0.6 V in steps of 0.1 V and in steps of 0.02 V from 0.6 to 0.76 V. In each step record the current flowing through the diode as I_F .
3. Tabulate different forward currents obtained for different forward voltages.

Reverse Bias Condition:

1. Connect the Zener diode in reverse bias as shown in the fig.2. Vary the voltage across the diode in steps of 1V from 0 V to 6 V and in steps 0.1 V till its breakdown voltage is reached. In each step note the current flowing through the diode
2. Plot a graph between V and I. This graph will be called the V-I characteristics of Zener diode. From the graph find out the breakdown voltage for the diode.

Observations:

Forward Bias Condition:

<u>Forward Voltage across the diode</u> <u>V_F (volts)</u>	<u>Forward Current through the diode</u> <u>I_F (mA)</u>

Reverse Bias Condition:

Reverse Voltage across the diode V_R (volts)									
Reverse Current through the diode I_R (mA)									

Graph:

1. Take a graph sheet and divide it into 4 equal parts. Mark origin at the center of the graph sheet.
2. Now mark +ve X-axis as V_F , -ve X-axis as V_R , +ve Y-axis as I_F and -ve Y-axis as I_R .
3. Mark the readings tabulated for forward biased condition in first Quadrant and reverse biased condition in third Quadrant

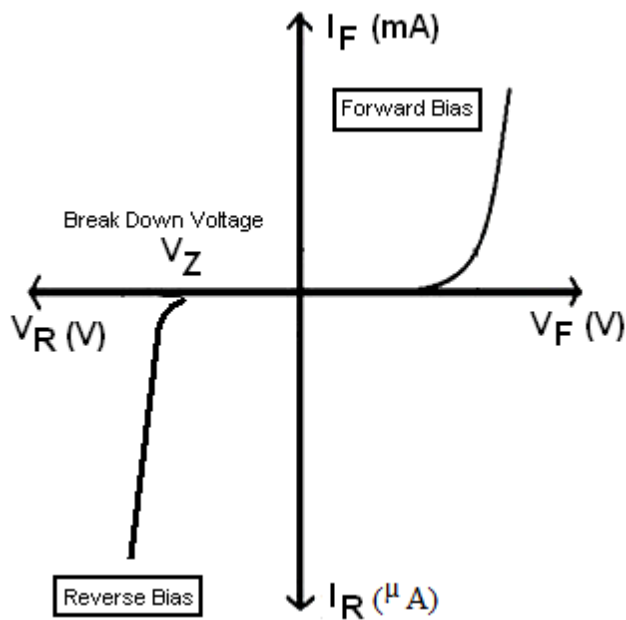

Figure 3 I-V Characteristics of Zener Diode

Calculations from Graph:

Precautions:

1. While doing the experiment do not exceed the readings of the diode. This may lead to damaging of the diode.
2. Connect voltmeter and ammeter in correct polarities as shown in the circuit diagram.
3. Do not switch ON the power supply unless you have checked the circuit connections as per the circuit diagram.

Results:

1. The Zener Diode Characteristics have been studied.
2. The breakdown voltage of Zener diode in reverse bias was found to be = _____

Questions

1. What is the difference between p-n Junction diode and zener diode?
2. What is break down voltage?
3. What are the applications of Zener diode?
4. What is cut-in-voltage ?
5. What is voltage regulator?